



VC20 Vessel Control System

Featuring simplified electrical management, a high-quality appearance, and significant functional improvements, the next generation YANMAR VC20 Vessel Control System integrates with YANMAR's complete line up of common rail engine series, transmissions, controls and displays.



FEATURES

- Newly designed control heads and switch panels with a high-quality appearance.
- Improved water resistance and natural feel push buttons on the control heads and switch panels.
- Enabling up to 4 helm stations.
- Synchronization and auto dimming ensures effective lighting of the equipment.
- Featuring fewer components, connections and cables.
- Reducing the number of helm ECUs to one for multiple station configurations by converting to CAN directly inside the control heads.
- Easier set up for faster installation and simpler maintenance and troubleshooting.

Multifunctional

The VC20 has been developed for single, twin, and triple engine installations. The new system offers dedicated control modes for all YANMAR control system functions including YANMAR joystick controls, JC10A for sterndrive applications and JC20A for inboard applications.

Compatibility

VC20 is applicable for YANMAR's common rail marine diesel engines for sail, power, and light duty commercial applications, including JH-CR, 4LV, 8LV, 6LY-CR, and the newly-launched 6LF and 6LT engine series.



SPECIFICATIONS

Product	Switch Panel	Control Head	VC20 Panel
Power supply range	DC 10 ~ 16V (12V)	DC 10 ~ 16V (12V)	DC 10 ~ 16V (12V)
Operating temperature limit	-30 to 65°C [-22 to 149°F]	-30 to 65°C [-22 to 149°F]	-30 to 65°C [-22 to 149°F]
Storage temperature range	-30 to 80°C [-22 to 176°F]	-30 to 80°C [-22 to 176°F]	-40 to 80°C [-40 to 176°F]
Water resistantance	Front: IPx7 Back: IPx6	Front: IPx7 Back: IPx6	Front: IPx7 Back: -
Product Weight	0.2 kg [0,4 lbs]	2.1 kg [4,6 lbs]	0.4 kg

DIMENSIONS

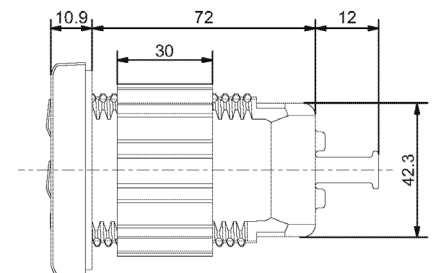
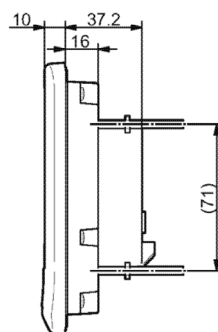
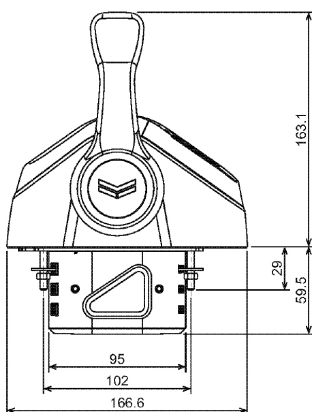
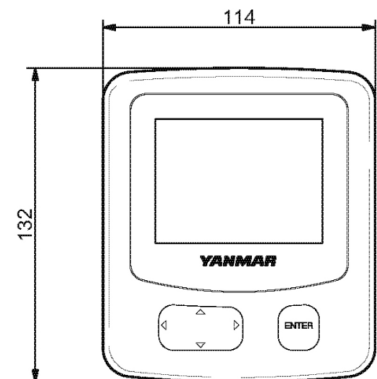
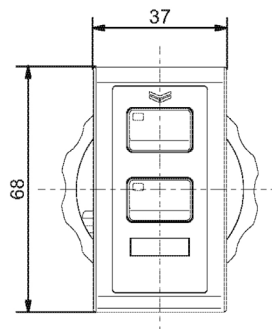
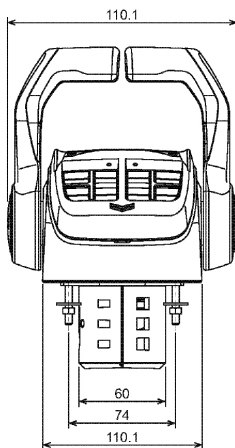

NOTE: All data subject to change without notice. Text and illustrations are not binding.