



# 6LF Series - 485 / 530 / 550

Configuration	in-line, 4-stroke, vertical, water-cooled diesel engine	
Max. output at crankshaft*	356 kW@3000 rpm	[485 mhp@3000 rpm]
	390 kW@3000 rpm	[530 mhp@3000 rpm]
	404 kW@3000 rpm	[550 mhp@3000 rpm]
No. of cylinders	6 cylinders	
Displacement	6.728 L	[411 cu in]
Bore x stroke	104 mm x 132 mm	[4.10 in x 5.20 in]
Aspiration	Turbocharged & intercooled	
Combustion system	Direct injection Bosch common rail system	
Starting system	Electric starting 12V - 3kW or 24V - 4kW	
Engine management	Electronic	
Cooling system	Fresh water cooling by centrifugal fresh water pump	
	Seawater cooling by rubber impeller seawater pump	
Alternator	12V - 90A, 24V - 70A	
Lubrication system	Enclosed, forced lubricating system	
Engine lube oil specifications	API class: CD or higher, SAE grade: 10W-30 or 15W-40	
Direction of rotation at crankshaft	Counterclockwise (CCW) viewed from stern	
Dry weight without gear	780 kg	[1720 lbs]
Engine dimensions† L x W x H	1519 x 893 x 881 mm	
Emission compliance	EU: RCD 2, EMC	US: EPA Tier 3**, IMO Tier 2
Flywheel housing size	SAE #3	
Controls	Electronic	

**NOTE:**

Fuel condition: Density at 15°C = 0.84 g/cm³; 1 kW = 1.3596 mhp = 1.3410 HP

Technical data is according to (ISO 8665)

\* Fuel temperature 40°C at the inlet of the fuel injection pump (ISO 8665)

\*\* The 6LF550 is not EPA Commercial certified.

†Length measured with with ZF280 gearbox & high-riser elbow (Dimensions may vary with other gears/elbow)

**DIMENSIONS**

**Gear view**

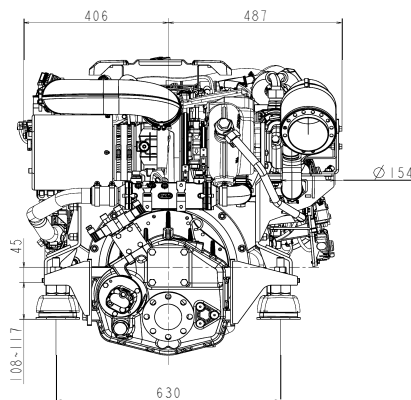

**Right side view**

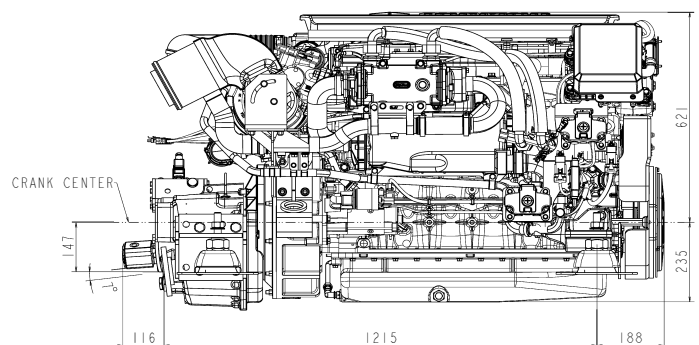

6LF with ZF280-1A gear  
(Not to be used for engine installation)



PERFORMANCE CURVES

6LF485 Torque curve

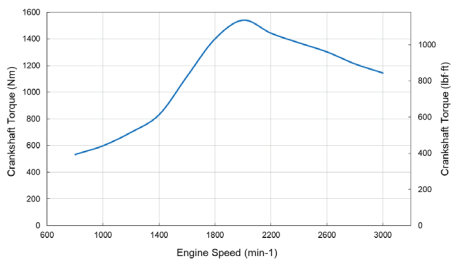

6LF485 Output Power curve

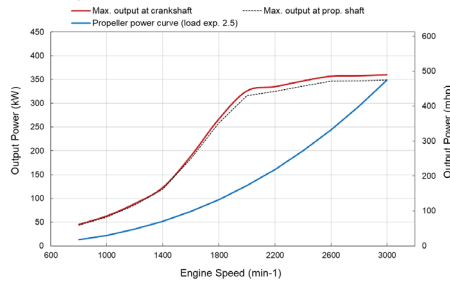

6LF485 Fuel consumption (load exp. 2.5)

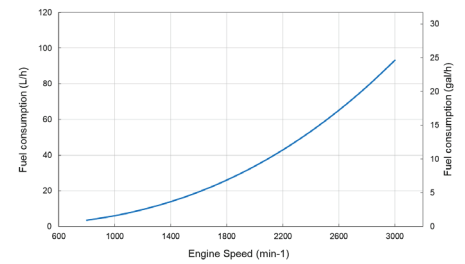

6LF530 Torque curve

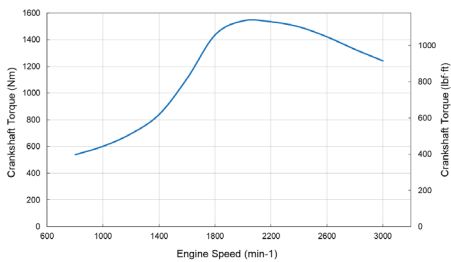

6LF530 Output Power curve

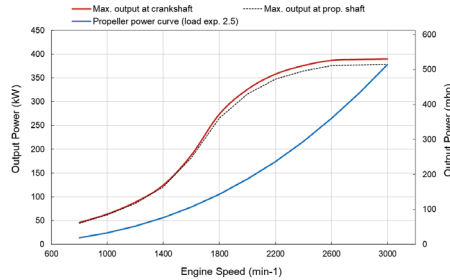

6LF530 Fuel consumption (load exp. 2.5)

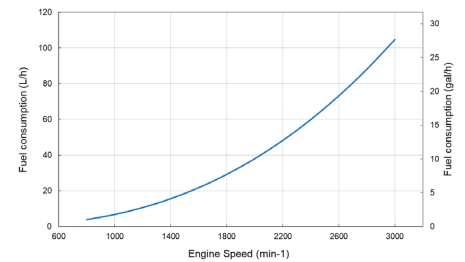

6LF550 Torque curve

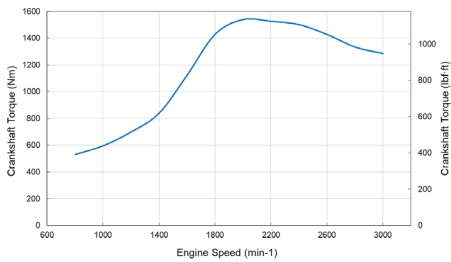

6LF550 Output Power curve

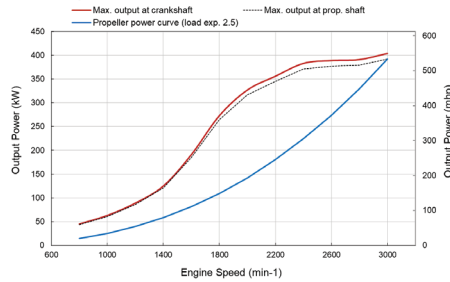

6LF550 Fuel consumption (load exp. 2.5)

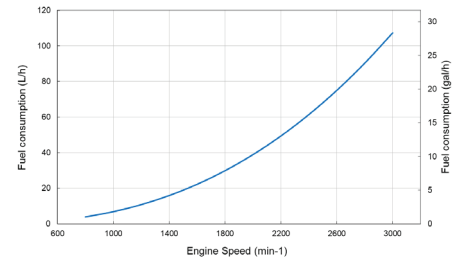

MARINE GEAR\*

<b>Model</b>	<b>ZF280-1A [Down angle: 7deg] / ZF280-1 [parallel]</b>
Clutch type	Hydraulic multi disc
Dry weight**	103 kg [227 lbs]
Reduction ratio [fwd/asn]	Gear ratio's available from ZF
Direction of rotation [viewed from stern]	Clockwise & counterclockwise
Lubrication system	Forced lubrication
Lube oil specifications	API class: CF or higher, SAE grade: #30
Max. lube oil capacity	4.5 L
Dry weight - engine & gear	883 kg [1947lbs]

\* Other marine gearboxes and configurations available upon request. Contact your local supplier for more information.

\*\* Dry weight including cooler, brackets & damper disk.

ACCESSORIES

**Standard engine package**

- Exhaust mixing elbow [high riser]
- 12V Electric system [single pole] / 24V Electric system [2-pole]
- Flexible mounts
- Alternator 12V - 90A / 24V - 70A
- VC20 Vessel Control System
- Electronic CAN-bus control head
- Backup Panel
- Lubrication oil evacuation pump [manual]
- Belt safety cover

**Optional accessories**

- Secondary alternator 24V - 110A including smart regulator
- Secondary alternator 12V - 125A or 24V - 65A [2-pole]
- Second or third station
- Hot water connector
- NMEA 2000 Engine monitoring system

- JC20A Inboard Joystick
- Extension harness [3m, 5m, 10m]
- Front PTO pulley
- Man Over Board Switch

NOTE: All data subject to change without notice. Text and illustrations are not binding.