



**YANMAR**  
®

***KMH***

**series**

**OPERATION MANUAL**

**KMH40A**

**KMH50A**

**KMH50V**

**P/N: 0AKMH-G00100**

**MARINE  
GEAR**

---

**Disclaimers:**

All information, illustrations and specifications in this manual are based on the latest information available at the time of publishing. The illustrations used in this manual are intended as representative reference views only. Moreover, because of our continuous product improvement policy, we may modify information, illustrations and / or specifications to explain and / or exemplify a product, service or maintenance improvement. We reserve the right to make any change at any time without notice. Yanmar and **YANMAR** are registered trademarks of Yanmar Co., Ltd. in Japan, the United States and / or other countries.

**All Rights Reserved:**

No part of this publication may be reproduced or used in any form by any means - graphic, electronic, or mechanical, including photocopying, recording, taping, or information storage and retrieval systems - without the written permission of Yanmar Marine International.

© 2006 Yanmar Marine International

1006

# TABLE OF CONTENTS

---

	Page
<b>Introduction</b> .....	1
Record of Ownership .....	2
<b>Safety</b> .....	3
Safety Precautions .....	3
General Information .....	4
Before You Operate .....	4
During Operation and Maintenance .....	5
<b>Product Overview</b> .....	9
Overview .....	9
Component Identification .....	10
Nameplate .....	12
Significance of Marine Gear Designations .....	12
Technical Data .....	13
<b>Marine Gear Operation</b> .....	15
Daily Checks .....	16
Visual Checks .....	16
Shifting the Marine Gear .....	18
Towing or Anchoring .....	18
<b>Maintenance</b> .....	19
Tightening Fasteners .....	22
Torque Charts .....	23
Standard Torque Values .....	23
Torque Specifications .....	23
Periodic Maintenance .....	24
The Importance of Periodic Maintenance .....	24
The Importance of Daily Checks .....	24
Keep a Log of Engine Hours and Daily Checks .....	24

# TABLE OF CONTENTS

---

Yanmar Replacement Parts .....	24
Tools Required .....	24
Ask Your Authorized Yanmar Marine Dealer or Distributor For Help .....	24
Periodic Maintenance Schedule .....	25
Periodic Maintenance Procedures .....	26
After Initial 50 Hours of Operation .....	26
Every 250 Hours of Operation .....	28
Every 1000 Hours of Operation .....	29
Long-Term Storage .....	30
<b>Troubleshooting</b> .....	31
Troubleshooting Chart .....	31
<b>Specifications</b> .....	33
General Specifications .....	33
Outline Drawings .....	34
KMH40A .....	34
KMH50A .....	35
KMH50V .....	36
<b>Optional Accessories</b> .....	39
Electric Shift Valve .....	39
Installation of Electric Shift Valve .....	39
Emergency Operation of Electric Valve .....	39
Trolling Valves .....	41
Mechanical Trolling Valve .....	41
Electric Trolling Valve .....	42
PTO Spline Sleeve and Flange .....	42
Specifications .....	42
Installation of the PTO Spline Sleeve and Flange .....	42

# INTRODUCTION

---

Welcome to the world of Yanmar Marine! Yanmar Marine offers engines, drive systems and accessories for all types of boats, from runabouts to sailboats, and from cruisers to mega yachts. In marine leisure boating, the worldwide reputation of Yanmar Marine is second to none.

Yanmar marine gears are designed for a wide range of applications. Our parallel, down angle, saildrive and V-drive marine gears are designed to reduce the vibration and make your cruising more pleasurable.

To help you enjoy your Yanmar Marine products for many years to come, please follow these recommendations:

- Read and understand this *Operation Manual* before you operate your boat to ensure that you follow safe operating practices and maintenance procedures.
- Keep this *Operation Manual* in a convenient place for easy access.
- If this *Operation Manual* is lost or damaged, order a new one from your authorized Yanmar marine dealer or distributor.
- Make sure this manual is transferred to subsequent owners. This manual should be considered a permanent part of the boat and remain with it.
- Constant efforts are made to improve the quality and performance of Yanmar products, so some details included in this *Operation Manual* may differ slightly from your marine gear. If you have any questions about these differences, please contact your authorized Yanmar marine dealer or distributor.

## INTRODUCTION

---

## RECORD OF OWNERSHIP

Take a few moments to record the information you need when you contact Yanmar for service, parts or literature.

**Marine Gear Model:** \_\_\_\_\_

**Marine Gear Serial No.:** \_\_\_\_\_

**Date Purchased:** \_\_\_\_\_

**Dealer:** \_\_\_\_\_

**Dealer Phone:** \_\_\_\_\_

# SAFETY

---

Yanmar considers safety of great importance and recommends that anyone that comes into close contact with its products, such as those who install, operate, maintain or service Yanmar products, exercise care, common sense and comply with the safety information in this manual and on the machine's safety labels. Keep the labels from becoming dirty or torn and replace them if they are lost or damaged. Also, if you need to replace a part that has a label attached to it, make sure you order the new part and label at the same time.



This safety alert symbol appears with most safety statements. It means attention, become alert, your safety is involved! Please read and abide by the message that follows the safety alert symbol.

## SAFETY PRECAUTIONS

### **DANGER**

Indicates a hazardous situation which, if not avoided, *will* result in death or serious injury.

### **WARNING**

Indicates a hazardous situation which, if not avoided, *could* result in death or serious injury.

### **CAUTION**

Indicates a hazardous situation which, if not avoided, *could* result in minor or moderate injury.

### **NOTICE**

Indicates a situation which can cause damage to the machine, personal property and / or the environment or cause the equipment to operate improperly.

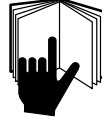
## General Information

There is no substitute for common sense and careful practices. Improper practices or carelessness can cause burns, cuts, mutilation, asphyxiation, other bodily injury or death. This information contains general safety precautions and guidelines that must be followed to reduce risk to personal safety. Special safety precautions are listed in specific procedures. Read and understand all of the safety precautions before operation or performing repairs or maintenance.

## Before You Operate

**⚠ DANGER**

The safety messages that follow have **WARNING** level hazards.



**NEVER** permit anyone to install or operate the engine or marine gear without proper training.

- Read and understand this *Operation Manual* before you operate or service the engine or marine gear to ensure that you follow safe operating practices and maintenance procedures.
- Safety signs and labels are additional reminders for safe operating and maintenance techniques.
- See your authorized Yanmar marine dealer or distributor for additional training.



## During Operation and Maintenance

### DANGER

The safety messages that follow have DANGER level hazards.

#### Fire Hazard



Keep fire extinguishers handy in case of fire. Clearly indicate the location of the fire extinguishers with a safety sign.

Ensure that the type of fire extinguishers are appropriate for material that might catch fire. Check with local authorities.

Have all fire extinguishers checked periodically for proper operation and / or readiness.

Post evacuation routes prominently. Periodically conduct fire drills.

Ensure that appropriate fire detection and extinguishing equipment are installed and checked periodically for proper operation. Check with local authorities.

### WARNING

The safety messages that follow have WARNING level hazards.

#### Explosion Hazard



Avoid serious personal injury or equipment damage. While the engine is running or the battery is charging, hydrogen gas is being produced and can be easily ignited. Keep the area around the battery well-ventilated and keep sparks, open flame and any other form of ignition out of the area.

Diesel fuel is flammable and explosive under certain conditions.

Never use a shop rag to catch the fuel. Wipe up all spills immediately.

#### Fire Hazard



Avoid injury or equipment damage from fire. Undersized wiring systems can cause an electrical fire.

#### Sever Hazard



NEVER service the marine gear while under tow or if the engine is running at idle speed. The propeller may rotate under these circumstances.

#### Alcohol and Drug Hazard



NEVER operate the engine while under the influence of alcohol or drugs or when feeling ill.

## WARNING

### Exposure Hazard



To avoid injury, ALWAYS wear personal protective equipment including appropriate clothing, gloves, work shoes, eye and hearing protection as required by the task at hand.

### Entanglement Hazard



NEVER leave the key in the key switch when you are servicing the engine or marine gear. Someone may accidentally start the engine and not realize you are servicing it.

Avoid personal injury. NEVER operate the engine while wearing a headset to listen to music or radio because it will be difficult to hear the warning signals.

If the vessel has more than one engine, NEVER service a marine gear if either of the engines are running. In multi-engine configurations, the propeller for an engine that is shut down may rotate if any of the other engines are running.

### Burn Hazard



Avoid serious injury. Some of the engine and marine gear surfaces become very hot during operation and shortly after shut-down. Keep hands and other body parts away from hot surfaces.

### Sudden Movement Hazard

Avoid personal injury. ALWAYS stop the engine before beginning service.

### Exhaust Hazard



Avoid serious injury or death. NEVER block windows, vents, or other means of ventilation if the engine is operating in an enclosed area. All internal combustion engines create carbon monoxide gas during operation and special precautions are required to avoid carbon monoxide poisoning.

**CAUTION**

The safety messages that follow have **CAUTION** level hazards.

**Poor Lighting Hazard**

Avoid personal injury or equipment damage. Ensure that the work area is adequately illuminated. **ALWAYS** install wire cages on portable safety lamps.

**Tool Hazard**

Avoid personal injury or equipment damage. **ALWAYS** use tools appropriate for the task at hand and use the correct size tool for loosening or tightening machine parts.

**Flying Object Hazard**

Avoid personal injury. **ALWAYS** wear eye protection when servicing the engine or when using compressed air or high-pressure water. Dust, flying debris, compressed air, pressurized water or steam may injure your eyes.

**NOTICE**

The safety messages that follow have **NOTICE** level hazards.

It is important to perform daily checks as listed in this *Operation Manual*. Periodic maintenance prevents unexpected downtime, reduces the number of accidents due to poor engine or marine gear performance and can help extend the life of the engine and marine gear.



**ALWAYS** be environmentally responsible.

Follow the guidelines of the EPA or other governmental agencies for the proper disposal of hazardous materials such as lubrication oil, diesel fuel and engine coolant. Consult the local authorities or reclamation facility.

**NEVER** dispose of hazardous materials by dumping them into a sewer, on the ground or into ground water or waterways.

Before operating the engine, check marine gear oil level.

## NOTICE

Observe the following environmental operating conditions to maintain marine gear performance and avoid premature marine gear wear:

- NEVER run the marine gear if the ambient temperature is above +45°C (+113°F) or below -15°C (+5°F).
- If the ambient temperature exceeds +45°C (+113°F) the marine gear may overheat and cause the marine gear oil to break down.
- If the ambient temperature falls below -15°C (+5°F) rubber components such as gaskets and seals will harden causing premature marine gear wear and damage.
- Contact your authorized Yanmar marine dealer or distributor if the marine gear will be operated in either temperature extreme.

---

NEVER attempt to modify the marine gear's design or safety features.

---

Observe the following environmental operating conditions to maintain marine gear performance and avoid premature marine gear wear:

- Avoid operating in extremely dusty conditions.
- Avoid operating in the presence of chemical gases or fumes.

---

If the marine gear oil temperature is too high, stop engine immediately and check the marine gear oil level and check the oil cooler for proper coolant and water flow.

### New Marine Gear Break-In:

On the initial engine start-up, allow the engine to idle for approximately 15 minutes while you check for proper marine gear function and marine gear oil leaks.

During the break-in period, carefully observe marine gear indicators (if any) for proper marine gear function.

During the break-in period, check the marine gear oil levels frequently.

# PRODUCT OVERVIEW

---

## OVERVIEW

The KMH marine gear is a hydraulically-activated helical gear unit, developed for use in pleasure craft.

The marine gear is equipped with a disk-type reversing clutch mounted on the support shaft and supplied with hydraulic pressure from an oil pump.

Operation of the oil pump is dependent on the engine speed.

The marine gear is lubricated by splash and force-feed lubrication.

# PRODUCT OVERVIEW

## COMPONENT IDENTIFICATION

Note: KMH40 shown. Other models are similar.

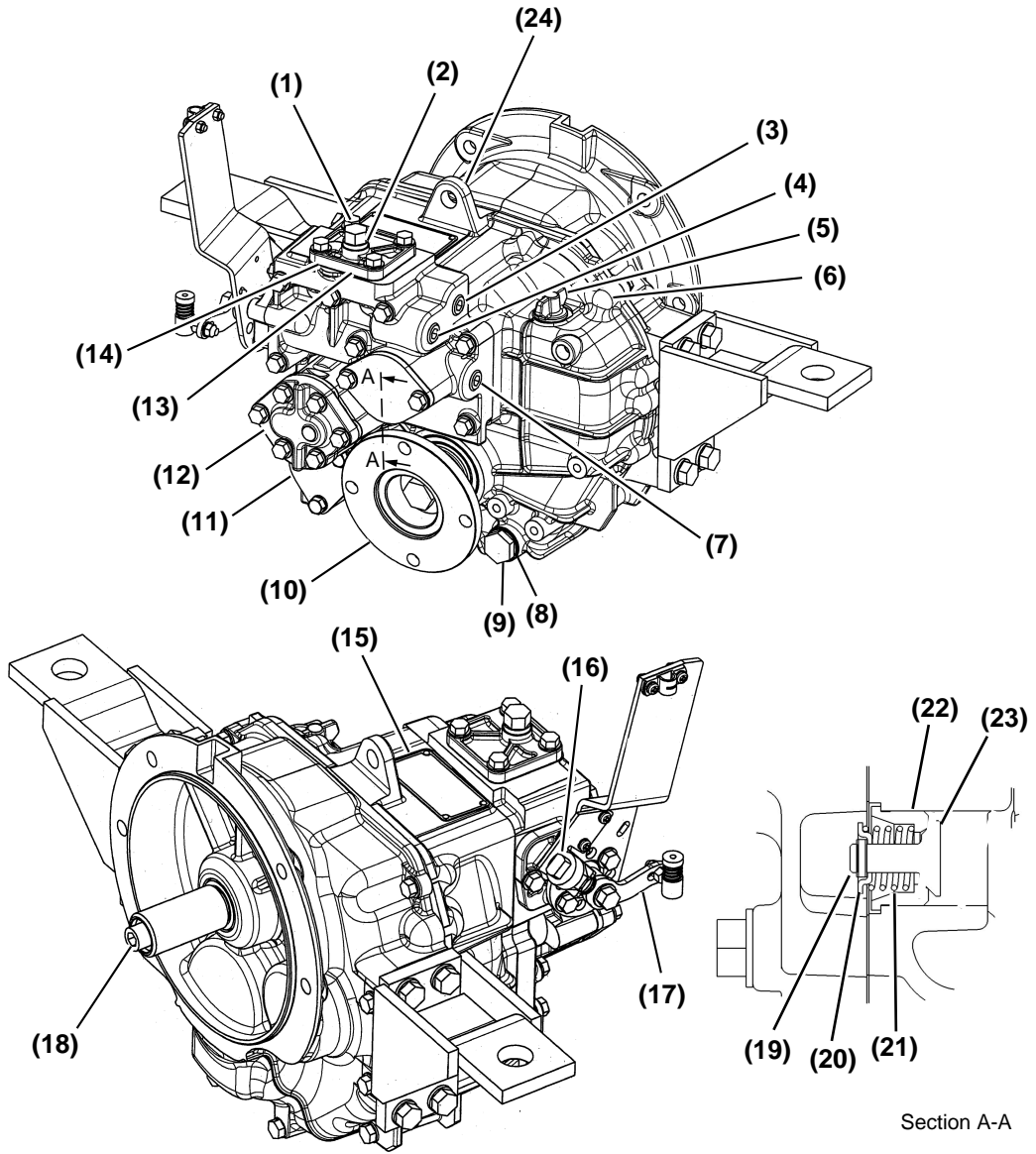


Figure 1

0004046A

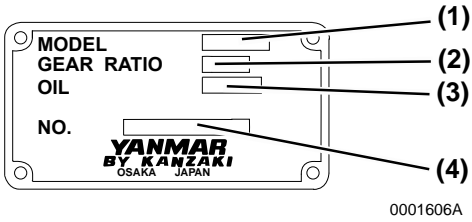
- |                                      |                              |
|--------------------------------------|------------------------------|
| 1 – Control Pressure Sensor Location | 13 – Gasket                  |
| 2 – O-Ring                           | 14 – Upper Cover             |
| 3 – Port to Heat Exchanger           | 15 – Nameplate               |
| 4 – Temperature Sensor Location      | 16 – Neutral Safety Switch   |
| 5 – Oil Dipstick                     | 17 – Shifting Lever          |
| 6 – Parallel Pin                     | 18 – Input Shaft             |
| 7 – Port from Heat Exchanger         | 19 – Spring Pin              |
| 8 – Seal Washer                      | 20 – Spring Retainer         |
| 9 – Drain Plug with Magnet           | 21 – Spring                  |
| 10 – Output Flange                   | 22 – 2nd Relief Shim         |
| 11 – Oil Strainer                    | 23 – 2nd Relief Valve        |
| 12 – Oil Pump                        | 24 – Marine Gear Lifting Eye |

NOTICE: *NEVER* use the marine gear lifting eye (**Figure 1, (24)**) to lift the engine and marine gear as an assembly. Use the engine lifting eyes to lift the engine and marine gear. Only use the marine gear lifting eye to lift the marine gear as a separate component.

# PRODUCT OVERVIEW

## NAMEPLATE

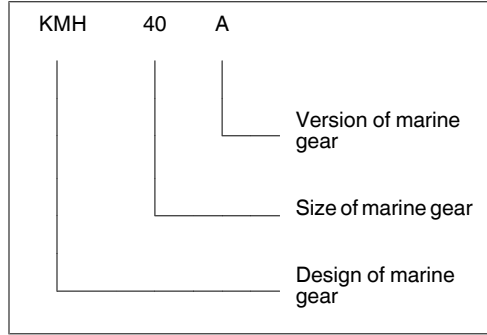
The nameplate is installed on the marine gear.



**Figure 2**

- 1 – Marine Gear Model**
- 2 – Marine Gear Ratio**
- 3 – Lubrication Oil Type**
- 4 – Marine Gear Serial Number**

## Significance of Marine Gear Designations





## TECHNICAL DATA

When installing the KMH marine gears, the following items should be specially noted:

- Installation should be done by a specialist only.
- Align and install the marine gear and engine correctly.
- Align correctly with engine and propeller shaft.
- Select a suitable damping coupling between the engine and the marine gear. See your authorized Yanmar dealer or distributor for assistance.
- Choose an adequate heat exchanger.
- Mount the marine gear correctly in the boat.

	<b>KMH40A</b>	<b>KMH50A</b>	<b>KMH50V</b>
Maximum Input Speed	5000 min <sup>-1</sup> (rpm)	4000 min <sup>-1</sup> (rpm)	5500 min <sup>-1</sup> (rpm)
Oil Capacity without Heat Exchanger			
Available	1.7 L (1.8 qt)	2.0 L (2.1 qt)	5.4 L (5.7 qt)
Effective	0.4 L (0.4 qt)	0.4 L (0.4 qt)	0.4 L (0.4 qt)

**This Page Intentionally Left Blank**

# MARINE GEAR OPERATION

---

This section of the *Operation Manual* describes the procedure for performing daily checks, checking the marine gear oil level and shifting the marine gear.

## WARNING

### Sever Hazard



Rotating parts can cause severe injury or death. NEVER wear jewelry, unbuttoned cuffs, ties or loose fitting clothing and ALWAYS tie long

hair back when working near moving / rotating parts such as the flywheel or PTO shaft. Keep hands, feet and tools away from all moving parts.

---

If the vessel has more than one engine, NEVER service a marine gear if either of the engines are running. In multi-engine configurations the propeller for an engine that is shut down may rotate if any of the other engines are running.

---

Shift the marine gear into the NEUTRAL position any time the engine is at idle.

### CAUTION

Periodic maintenance prevents unexpected downtime, reduces the number of accidents due to poor machine performance and helps extend the life of the marine gear.

If any problem is noted during the visual check, the necessary corrective action should be taken before you operate the marine gear.

## DAILY CHECKS

All marine gears have been submitted to a test run before shipment.

Visual checks for leakage should be made from time to time.

Before operating the marine gear, make sure it is in good operating condition. Make sure you check the following items and have any repairs completed before you operate the marine gear.

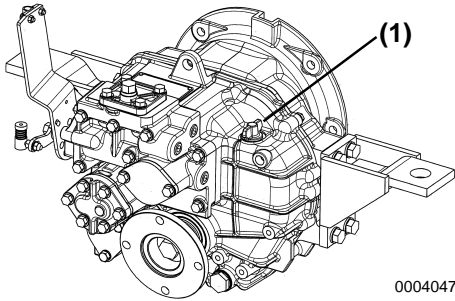
### Visual Checks

***CAUTION! If any problem is noted during the visual check, the necessary corrective action should be taken before you operate the marine gear.***

1. Check for oil leaks.
2. Check for damaged or missing parts.
3. Check for loose, missing or damaged fasteners.
4. Check the electrical harnesses for cracks, abrasions, and damaged or corroded connectors.

## Checking Oil Level

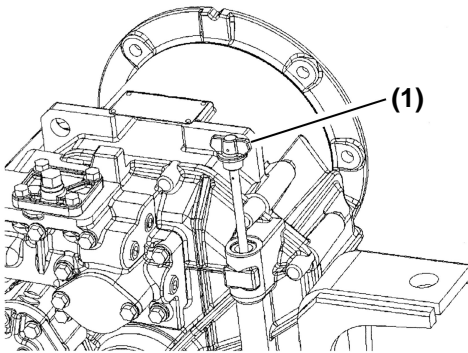
### KMH40A and KMH50A



0004047

**Figure 1**

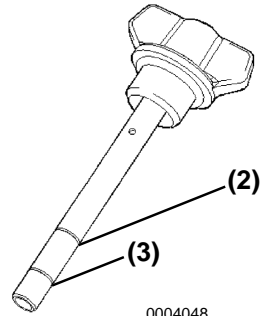
### KMH50V



0004426A

**Figure 2**

1. **NOTICE:** Prevent dirt and debris from contaminating marine gear oil. Carefully clean the dipstick and surrounding area before you remove it. Remove dipstick (**Figure 1, (1)**) or (**Figure 2, (1)**) and wipe with clean cloth.
2. Reinsert the dipstick but do not thread it into place.



0004048

**Figure 3**

3. Remove the dipstick. The oil level should be between the upper (**Figure 3, (2)**) and lower (**Figure 3, (3)**) lines on dipstick.
4. Insert dipstick and tighten securely.
5. Ensure the shift lever is in NEUTRAL.
6. Start the engine. Let the engine run at idle with the shift lever in the NEUTRAL position for several minutes. This will ensure the oil is distributed to all pipelines, oil cooler and marine gear oil passages.
7. Stop the engine. WAIT AT LEAST 10 MINUTES for the oil to drain back into the sump.
8. Check the oil level. If necessary, add oil until the level reaches the upper mark on the dipstick. Check the oil level again after operating the marine gear for a short period of time. **NOTICE:** Never overfill. The oil level must be between the upper and lower level marks.

### Recommended Oil (Type of Oil)

- **API (American Petroleum Institute) service grade:** Class CF or higher
- **Viscosity:** SAE 30
- **Recommended oil:** Yanmar Marine Super Oil SAE 30.

**NOTICE:** ALWAYS use the specified SAE 30 oil. NEVER use gear oil or ATF in KMH marine gears. NEVER use multi-grade oil or mix oil types.

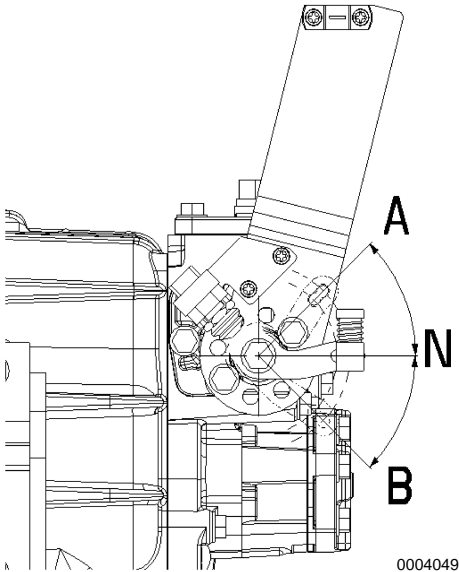
### SHIFTING THE MARINE GEAR

**NOTICE:** *During normal operation, the marine gear should only be shifted with the engine at idle. Shifting at higher engine speed will damage the marine gear.*

The marine gear is shifted by moving the shifting lever.

#### Shifting Positions:

- A = Propeller rotation opposite of engine rotation.
- N = NEUTRAL position
- B = Propeller rotation same as engine rotation.



**Figure 4**

Operating temperature of the marine gear:  
50° to 80°C (122° to 176°F).

A connection port for a temperature sensor has been provided. (See *Component Identification* on page 10).

### TOWING OR ANCHORING

When a boat is being towed or is anchored, water current will cause the propeller to turn (when the engine is off, the position of the shifting lever is irrelevant). This will not cause damage to the marine gear. In a boat with two engines, the propeller of the unused marine gear may rotate freely.

# MAINTENANCE

---

This section of the *Operation Manual* describes the procedures for proper care and maintenance of the marine gear.



## **⚠ CAUTION**

NEVER permit anyone to install or operate the marine gear without proper training. Safety signs and labels are additional reminders for safe service and maintenance techniques.

---

Read and understand this *Operation Manual* before you operate or service the marine gear to ensure that you follow safe servicing practices and maintenance procedures.

### **DANGER**

#### **Crush Hazard**



ALWAYS use lifting equipment with sufficient capacity to lift marine gear.

---

NEVER stand under hoisted marine gear. If the hoist mechanism fails, the marine gear will fall on you, causing serious injury or death.

---

NEVER support marine gear with equipment not designed to support the weight of the marine gear such as wooden pieces, blocks or by only using a jack.

### **WARNING**

#### **Sudden Movement Hazard**

When you install the “emergency nut” the boat will move as soon as you start the engine! Make sure the area is clear before you start the engine.

---

#### **Sever Hazard**



Rotating parts can cause severe injury or death. NEVER wear jewelry, unbuttoned cuffs, ties or loose fitting clothing and ALWAYS tie long

hair back when working near moving / rotating parts such as the flywheel or PTO shaft. Keep hands, feet and tools away from all moving parts.

---

To prevent accidental equipment movement, NEVER start the engine in gear.

---

Before starting the engine, ALWAYS make sure that all bystanders are clear of the area. Keep children and pets away while the engine is operating.

---

Avoid personal injury or equipment damage. Always remove any tools or shop rags used during maintenance from the area before operation.

---

NEVER service the marine gear while under tow or if the engine is running at idle speed. The propeller may rotate under these circumstances.

---

Stop the engine before you begin to service the marine gear and secure the propeller so it will not turn.



**Entanglement Hazard**

NEVER leave the key in the key switch when you are servicing the engine or marine gear. Someone may accidentally start the engine and not realize you are servicing it.

Avoid unexpected equipment movement. Shift the marine gear into the NEUTRAL position any time the engine is at idle.

**Electrical Shock Hazard**



Avoid serious personal injury or equipment damage. ALWAYS turn off the battery switch (if equipped) or disconnect the negative

battery cable before servicing the equipment.

Avoid personal injury or equipment damage. ALWAYS keep the electrical connectors and terminals clean. Check the electrical harnesses for cracks, abrasions, and damaged or corroded connectors.

**⚠ CAUTION**

**Slipping and Tripping Hazard**



Ensure that adequate floor space is set aside for servicing marine gear. The floor space must be flat and free of holes.

Keep floor free of dust, mud, spilled liquids and parts to help prevent slipping and tripping.

### NOTICE

Always tighten components to the specified torque. Loose parts can cause equipment damage or cause it to operate improperly.

Only use replacement parts specified. Other replacement parts may affect warranty coverage.

NEVER attempt to modify the marine gear's design or safety features.

Failure to comply may impair the marine gear's safety and performance characteristics and shorten the marine gear's life. Any alterations to this marine gear may affect the warranty coverage of your marine gear.

NEVER use the marine gear lifting eye to lift the engine and marine gear as an assembly. Use the engine lifting eyes to lift the engine and marine gear. Only use the marine gear lifting eye to lift the marine gear as a separate component.

## TIGHTENING FASTENERS

Use the correct amount of torque when tightening fasteners. Applying excessive torque may damage the fastener or component and too little torque may cause a leak or component failure.



The tightening torque in the Standard Torque Chart should be applied only to the bolts with a "7" head. (JIS strength classification: 7T).

Apply 60% torque to bolts that are not listed.

Apply 80% torque when tightened to aluminum alloy.

# TORQUE CHARTS

## Standard Torque Values

	M6 x 1.0	M8 x 1.25	M10 x 1.25 or 1.5	M12 x 1.25 or 1.5	M14 x 1.5	M16 x 1.5
Cast Iron or Steel	10.8 ± 1.0 N·m 8.0 ± 0.8 ft-lb	25.5 ± 2.0 N·m 18.8 ± 1.5 ft-lb	49.1 ± 4.9 N·m 36.2 ± 3.6 ft- lb	88.3 ± 10.0 N·m 65.1 ± 7.4 ft-lb	137.2 ± 4.9 N·m 101.2 ± 3.6 ft-lb	225.4 ± 10.0 N·m 166.2 ± 7.4 ft-lb
Aluminum	8.8 ± 1.0 N·m 6.5 ± 0.8 ft-lb	20.6 ± 2.0 N·m 15.2 ± 1.5 ft-lb	39.2 ± 2.0 N·m 28.9 ± 1.5 ft-lb	70.6 ± 4.9 N·m 52.1 ± 3.6 ft-lb	109.8 ± 4.9 N·m 81.0 ± 3.6 ft-lb	180.3 ± 10.0 N·m 133.0 + 7.4 ft-lb

## Torque Specifications

Item	Size	Torque		Comments
Shift Lever Bolt	M10 x 1.5	39.2 ± 2.0 N·m	28.9 ± 1.5 ft-lb	
Tapered Plugs	FPTF 3/8	39.2 ± 2.0 N·m	28.9 ± 1.5 ft-lb	Do not use sealing tape
Drain Plugs	M16 x 1.5	29.4 ± 2.0 N·m	21.7 ± 1.5 ft-lb	
Neutral Safety Switch	M12 x 1.25	3.2 ± 2.0 N·m	2.4 ± 1.5 ft-lb	
Hose Clamps for Cooler		2.5 - 3.4 N·m	1.8 - 2.5 ft-lb	
Hose for Cooler	3/4 - 16	49 ± 0.49 N·m	36.1 ± 0.36 ft-lb	
Transmission Assembly Bolts	M8	18.6 - 22.6 N·m	13.7 - 16.7 ft-lb	
	M10	37.2 - 41.2 N·m	27.5 - 30.4 ft-lb	
	M12	65.7 - 75.5 N·m	48.5 - 55.7 ft-lb	
Output Coupling Bolt	M16	215.4 - 235.4 N·m	158.8 - 173.6 ft-lb	KMH40A and KMH50A
Dipstick		Hand-Tighten		

## PERIODIC MAINTENANCE

**CAUTION!** *Establish a periodic maintenance plan according to the marine gear application and make sure you perform the required periodic maintenance at intervals indicated. Failure to follow these guidelines will impair the marine gear's safety and performance characteristics, shorten the marine gear's life and may affect the warranty coverage on your marine gear. See your authorized Yanmar marine dealer or distributor for assistance when checking items marked with a ●.*

### The Importance of Periodic Maintenance

Marine gear deterioration and wear occur in proportion to the length of time the marine gear has been in service and the conditions it is subjected to during operation. Periodic maintenance prevents unexpected downtime, reduces the number of accidents due to poor machine performance and helps extend the life of the marine gear.

### The Importance of Daily Checks

The Periodic Maintenance Schedule assumes that the daily checks are performed on a regular basis. Make it a habit of performing daily checks before the start of each operating day. *See Daily Checks on page 16* and refer to the *Operation Manual* for your engine.

### Keep a Log of Engine Hours and Daily Checks

Keep a log of the number of hours the engine is run each day and a log of the daily checks performed. Also note the date, type of repair (e.g., replaced bearings), and parts used for any service needed between the periodic maintenance intervals. Periodic maintenance intervals are every 250 engine hours. Failure to perform periodic maintenance will shorten the life of the marine gear.

## Yanmar Replacement Parts

Yanmar recommends that you use genuine Yanmar parts when replacement parts are needed. Genuine replacement parts help ensure long engine life.

## Tools Required

Before you start any periodic maintenance procedure, make sure you have the tools you need to perform all of the required tasks.

## Ask Your Authorized Yanmar Marine Dealer or Distributor For Help

Our professional service technicians have the expertise and skills to help you with any maintenance or service related procedures.

Daily and periodic maintenance is important to keep the marine gear in good operating condition. The following is a summary of maintenance items by periodic maintenance intervals. Periodic maintenance intervals vary depending on marine gear application and are hard to establish definitively. The following should be treated only as a general guideline.

*Note:* These procedures are considered normal maintenance and are performed at the owner's expense.

**Periodic Maintenance Schedule**

○: Check ◇: Replace ●: Contact your authorized Yanmar marine dealer or distributor					
System	Item	Periodic Maintenance Interval			
		Daily	After Initial 50 hours	Every 250 hours or one year whichever comes first	Every 1000 hours or 4 years whichever comes first
Whole	Visual inspection of marine gear exterior	○ Before starting			
Lubricating System	Check the marine gear oil level and refill if necessary	○ Before starting			
	Change the marine gear oil and clean the oil strainer		◇	◇	
	Change electric trolling valve oil filter element (if equipped)		◇		◇

# MAINTENANCE

## PERIODIC MAINTENANCE PROCEDURES

### After Initial 50 Hours of Operation

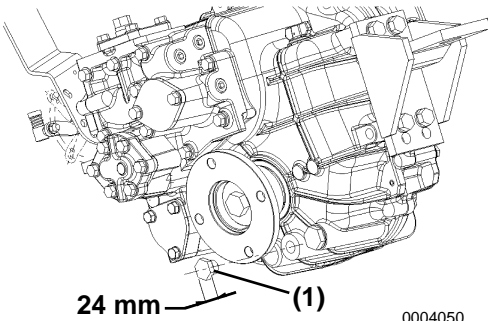
Perform the following maintenance after the initial 50 hours of operation.

- Changing the Marine Gear Oil and Cleaning the Marine Gear Oil Strainer
- Changing the Electric Trolling Valve Oil Filter Element (If Equipped)

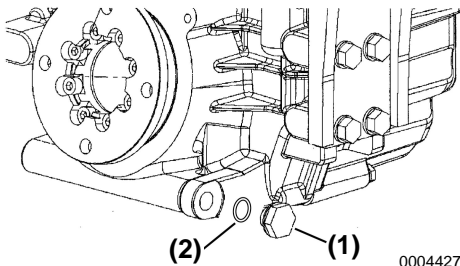
### Changing the Marine Gear Oil and Strainer

Optimum effectiveness of oil can only be assured if the marine gear oil is changed and the oil strainer is washed with clean oil regularly, according to the maintenance schedule.

1. Position a container under the marine gear to collect the waste oil.  
**KMH40A and KMH50A**



**Figure 1**  
**KMH50V**



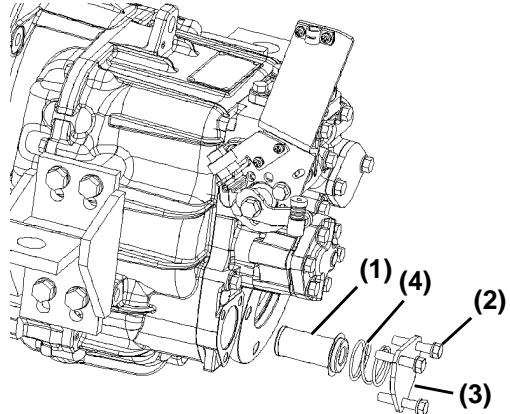
**Figure 2**

2. Use a 24 mm wrench to remove the M16 drain plug (**Figure 1, (1)**) or (**Figure 2, (1)**) and seal washer (**Figure 2, (2)**).

*Note:* Clean any metal particles from the drain plug with magnet before installing in housing.

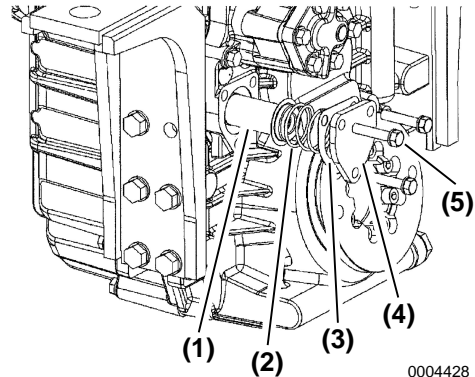
3. Check the seal washer for damage. Replace if necessary.

### KMH40A and KMH50A



0004051

**Figure 3**  
**KMH50V**



0004428

**Figure 4**

4. Remove three M8x40 bolts (**Figure 3, (2)**) or (**Figure 4, (5)**) and washers.

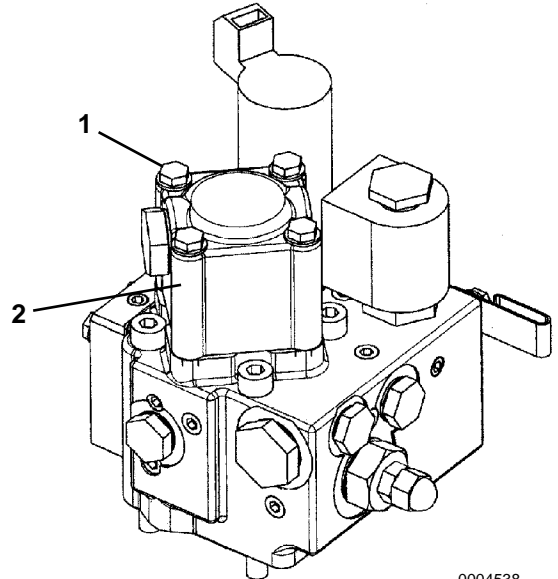
5. Remove the cover (**Figure 3, (3)**) or (**Figure 4, (4)**), cover gasket (**Figure 4, (3)**), spring (**Figure 3, (4)**) or (**Figure 4, (2)**) and oil strainer (**Figure 3, (1)**) or (**Figure 4, (1)**).
6. Check the cover gasket for damage. Replace if necessary.

**Note:** The oil strainer (**Figure 3, (1)**) or (**Figure 4, (1)**) must be washed with clean oil whenever the oil is changed.

7. Install the oil strainer, spring, gasket and cover.
8. Tighten the cover bolts to 18.6 - 20.6 N·m (13.7 - 15.2 ft·lb).
9. Remove the dipstick. Fill with the following quantities of oil, and add the amount required for oil cooler and pipelines. **NOTICE: Avoid engine damage. Never overfill the marine gear. The oil level must be between the upper and lower level marks on the dipstick.**
  - Quantities of oil: See *Technical Data* on page 13.
  - Type of oil: See *Recommended Oil (Type of Oil)* on page 17.
10. After filling the marine gear with oil, reinstall the dipstick and hand-tighten. Over-tightening may damage the cap.
11. Perform a trial run after the oil change.
12. Ensure the shift lever is in the NEUTRAL position.
13. Start the engine. Let the engine idle with the shift lever in the NEUTRAL position for several minutes. This will ensure the oil is distributed to all pipelines and the oil cooler.
14. Stop the engine. **WAIT AT LEAST 10 MINUTES** for the oil to drain back into the sump.
15. Check oil level. See *Checking Oil Level* on page 17. If necessary, add oil until the level reaches the upper mark on the dipstick. Check the oil level again after operating the marine gear for a short period of time.

## Changing the Electric Trolling Valve Oil Filter Element (If Equipped)

1. Remove four mounting bolts (**Figure 5, (1)**) from electric trolling valve (**Figure 5, (2)**).

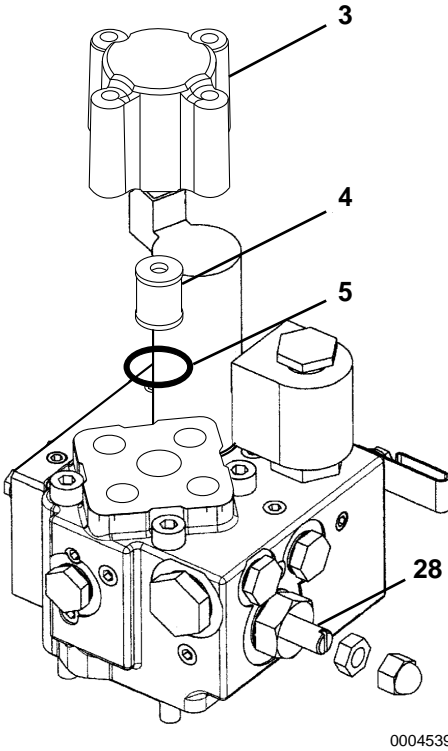


**Figure 5**

0004538

## MAINTENANCE

2. Remove filter element housing (**Figure 6, (3)**).



**Figure 6**

3. Remove filter element (**Figure 6, (4)**).
4. Remove and replace O-ring (**Figure 6, (5)**).
5. Install new filter element.
6. Installing filter element housing.
7. Install four mounting bolts.

### Every 250 Hours of Operation

Perform the following maintenance every 250 hours of operation or yearly, whichever comes first.

- **Changing the Marine Gear Oil and Cleaning the Marine Gear Oil Strainer**

#### **Changing the Marine Gear Oil and Cleaning Strainer**

See *Changing the Marine Gear Oil and Strainer* on page 26.



## Every 1000 Hours of Operation

Perform the following maintenance every 1000 hours of operation or every 4 years, whichever comes first.

- **Changing the Electric Trolling Valve Oil Filter Element (If Equipped)**

### **Changing the Electric Trolling Valve Oil Filter Element (If Equipped)**

*See Changing the Electric Trolling Valve Oil Filter Element (If Equipped) on page 27.*

### LONG-TERM STORAGE

If the marine gear is stored for six months or longer, oil should be added through the dipstick hole to full mark to protect the unit from corrosion.

Drain seawater from the cooling system, including the gear oil cooler.

Before operating the marine gear after a long-term storage, the marine gear oil must be changed. *See Changing the Marine Gear Oil and Strainer on page 26.*

# TROUBLESHOOTING

## TROUBLESHOOTING CHART

Before performing troubleshooting, verify that all items of the operating instructions have been complied with.

The following chart will assist in troubleshooting. **CAUTION! If any indicator fails to illuminate when the key switch is in the ON position, see your authorized Yanmar Marine dealer or distributor for service before operating the engine and marine gear.**

No.	Problem	Possible Cause	Action
1	High oil temperature	Oil level high during operation	Pump out oil until oil level is at maximum mark on dipstick.
		Oil level low	Add oil.
		Plugged or restricted heat exchanger	Replace heat exchanger and flush water system.
		No coolant in cooling system	Check cooling system and repair.
		Unknown	See your authorized Yanmar marine dealer or distributor.
2	Oil on marine gear housing	Loose screws	Tighten to specification.
		Loose hardware	Tighten or replace.
		Loose dipstick	Tighten or replace.
		Loose oil strainer	Tighten or replace.
		Oil level too high during operation	Pump out oil until oil level is at maximum mark on dipstick.
		Unknown	See your authorized Yanmar marine dealer or distributor.
3	Oil and water mixed	Damaged heat exchanger	See your authorized Yanmar marine dealer or distributor.
4	Shifts hard	Selector control	See your authorized Yanmar marine dealer or distributor.
		Linkage	See your authorized Yanmar marine dealer or distributor.
		Unknown	See your authorized Yanmar marine dealer or distributor.

## TROUBLESHOOTING

No.	Problem	Possible Cause	Action
5	Slow engagement	Selector control	See your authorized Yanmar marine dealer or distributor.
		Low oil level	Add oil.
		Linkage	See your authorized Yanmar marine dealer or distributor.
		Unknown	See your authorized Yanmar marine dealer or distributor.
6	No movement of the boat	Selector control	See your authorized Yanmar marine dealer or distributor.
		Improper selector position	Adjust.
		Low oil level	Add oil.
		Propeller missing	Replace.
		Propeller shaft broken	See your authorized Yanmar marine dealer or distributor.
		Marine gear malfunction	See your authorized Yanmar marine dealer or distributor.
Engine malfunction	See your authorized Yanmar marine dealer or distributor.		

# SPECIFICATIONS

## GENERAL SPECIFICATIONS

Item	Specification				
	KMH40A		KMH50A		KMH50V
Type	Down Angle Hydraulic				V-Drive Hydraulic
Angle	8°				12°
Maximum Input Speed	5000 min <sup>-1</sup> (rpm)	5000 min <sup>-1</sup> (rpm)	4000 min <sup>-1</sup> (rpm)	4000 min <sup>-1</sup> (rpm)	5500 min <sup>-1</sup> (rpm)
Direction of Rotation	Input	Counterclockwise viewed from stern			Clockwise viewed from stern
	Output	Clockwise or Counterclockwise viewed from stern			
Shift	Mechanical Cable or Electrical (Optional)				
Lubrication	Forced Lubrication				
Oil Capacity	1.7 L (1.8 qt)		2.0 L (2.1 qt)		5.4 L (5.7 qt)
Bellhousing Size	Borg Warner or SAE #4 Flange				Borg Warner
Dry Weight	29.5 kg (65 lb) without oil cooler, damper, feet or SAE #4 housing		41 kg (90 lb) without oil cooler, damper, feet or SAE #4 housing		59 kg (130 lb) without oil cooler, damper or feet

KMH40A

Borg Warner Flange

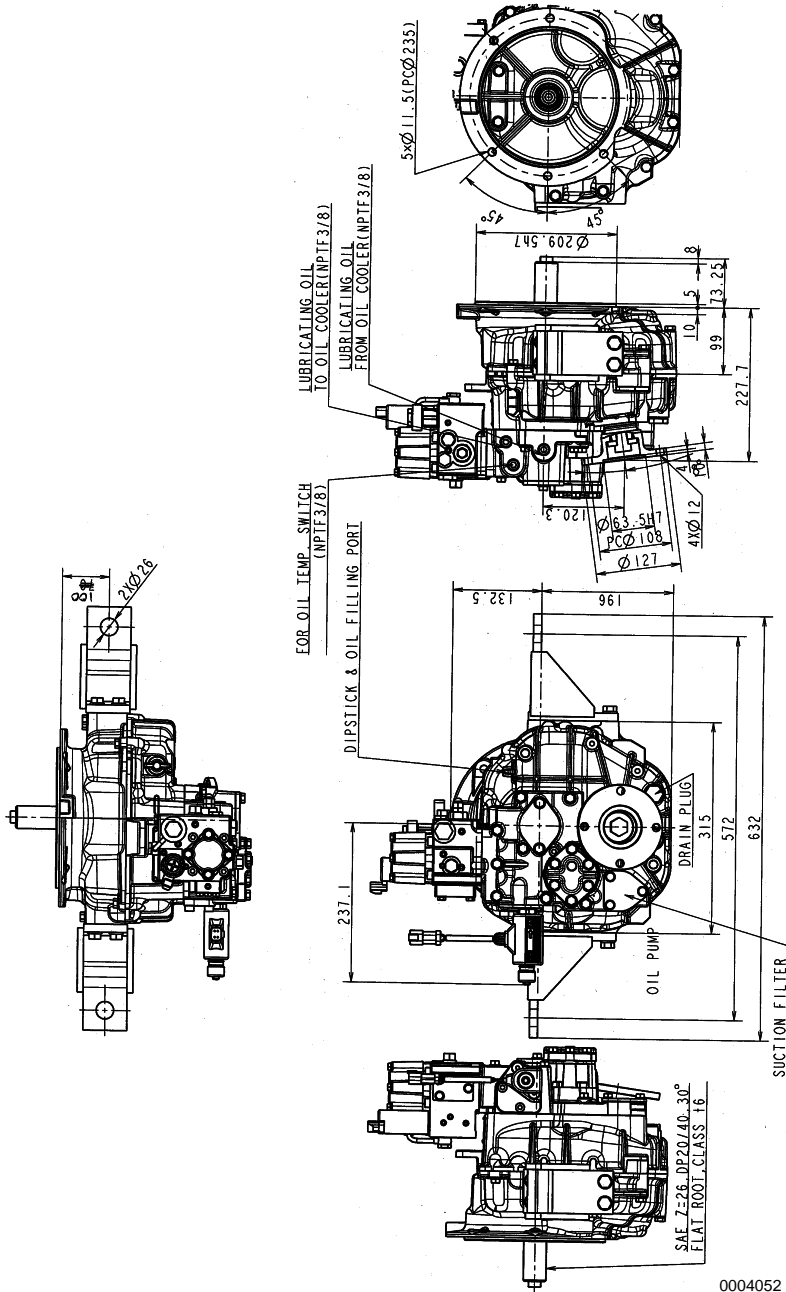
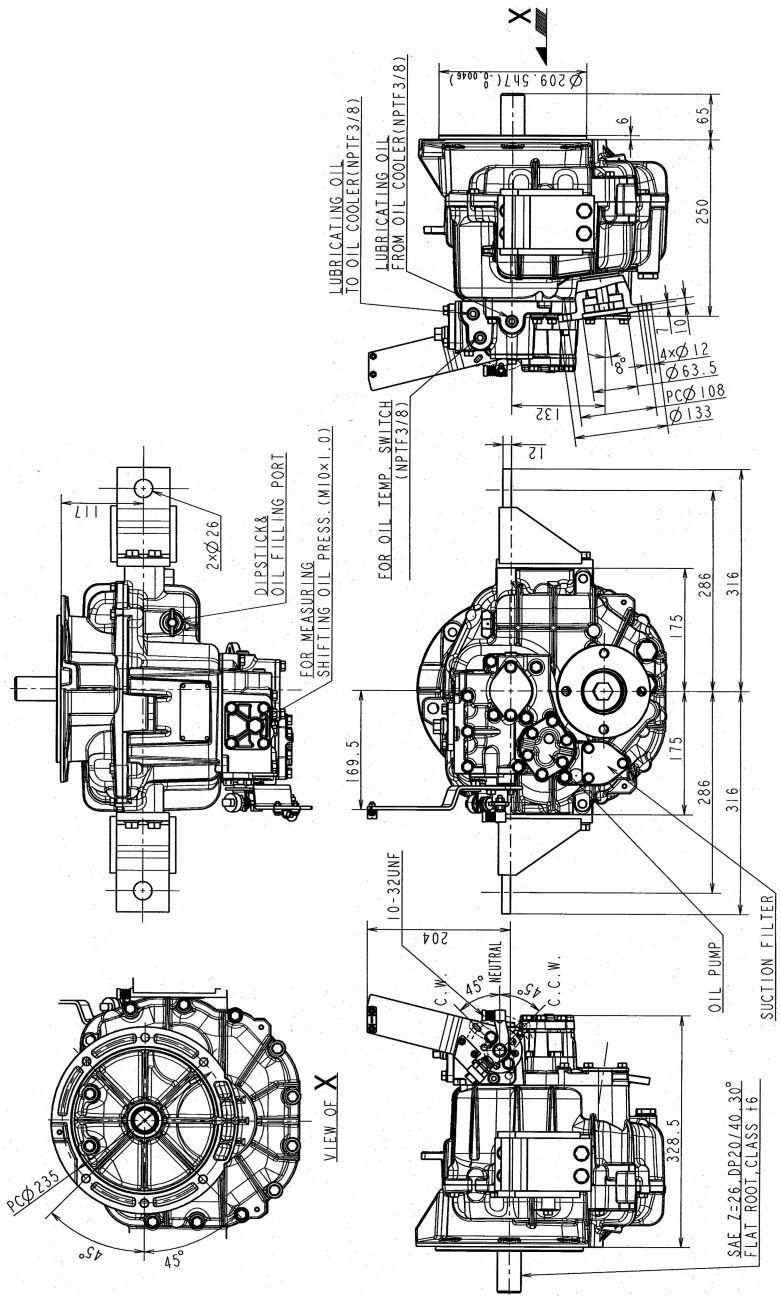


Figure 1

0004052

KMH50A

Borg Warner Flange



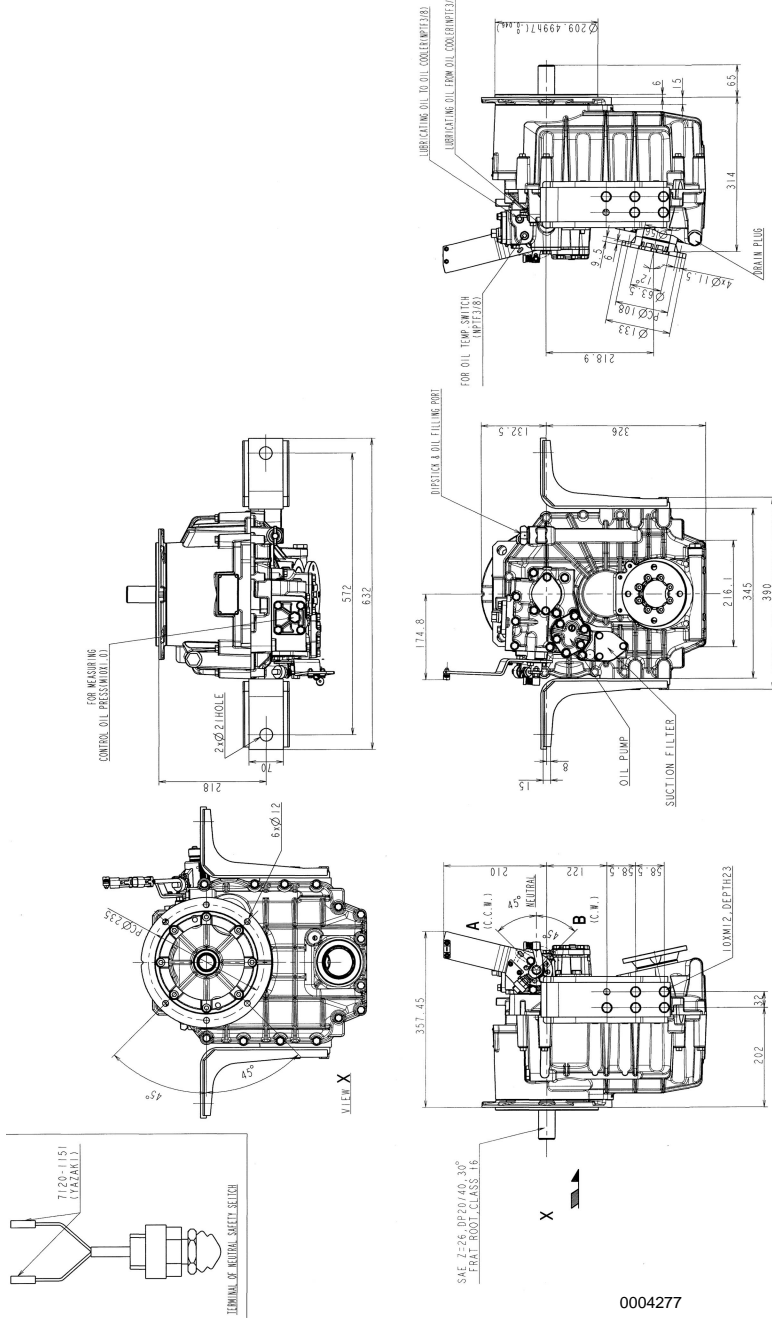
0004054

Figure 2

# SPECIFICATIONS

## KMH50V

### Mechanical Shift

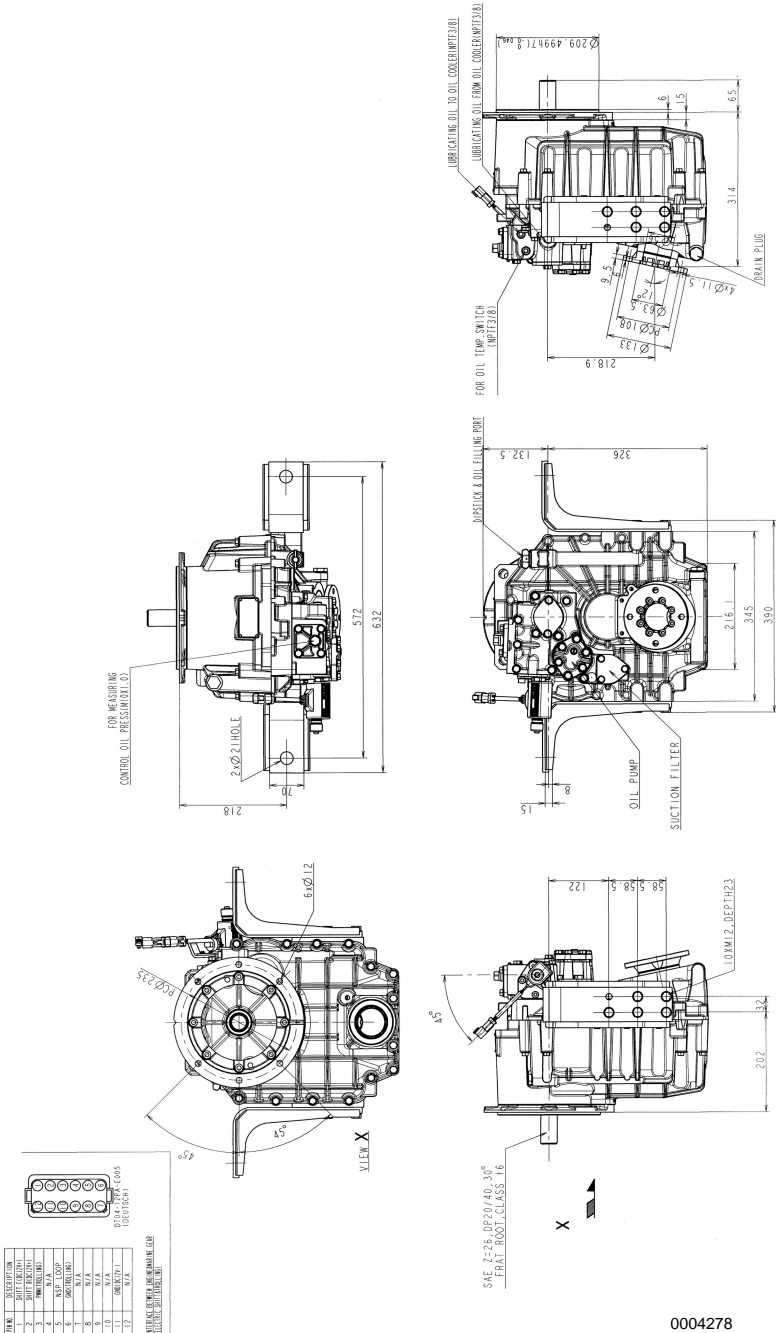


0004277

Figure 3



Electronic Shift



0004278

Figure 4

**This Page Intentionally Left Blank**

# OPTIONAL ACCESSORIES

## ELECTRIC SHIFT VALVE

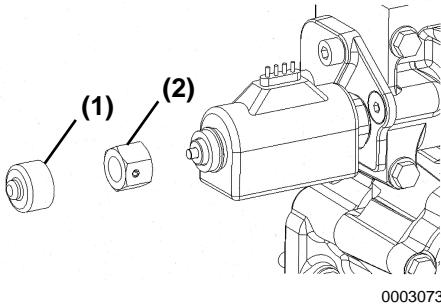
### Installation of Electric Shift Valve

See your authorized Yanmar dealer or distributor for assistance.

### Emergency Operation of Electric Valve

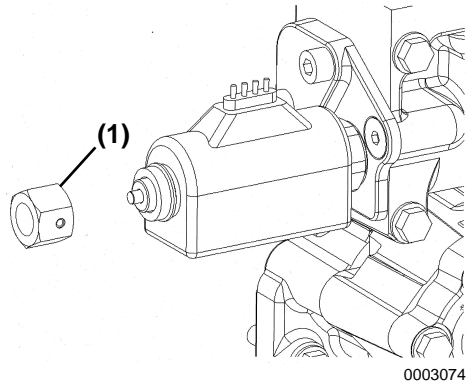
If the electric valve stops operating with the engine(s) not running, do the following:

#### Current Production Models



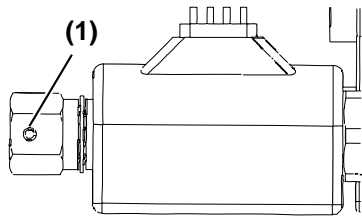
**Figure 1**

1. With the engine(s) not running, remove cap (**Figure 1, (1)**), and emergency nut (**Figure 1, (2)**). **CAUTION! If you have more than one engine, you cannot shift the marine gear into the “B” position after you install the “emergency nut.”**

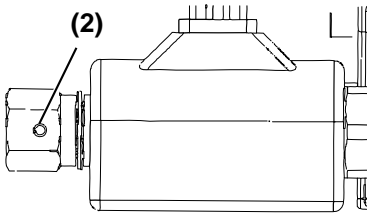


**Figure 2**

2. Reverse the emergency nut (**Figure 2, (1)**) and thread it onto electric valve. **WARNING! When you reverse the “emergency nut” the transmission is locked in gear and the boat will move as soon as you start the engine! There is no neutral safety protection in this mode. Make sure the area is clear before you start the engine.**



Normal Operation



Emergency Operation

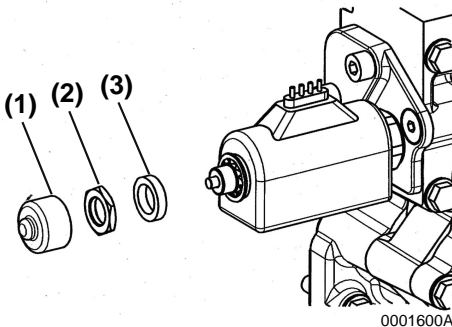
0003075

**Figure 3**

Note the orientation of the spring pin in the emergency nut.

- Normal operation (**Figure 3, (1)**)
- Emergency operation (**Figure 3, (2)**)

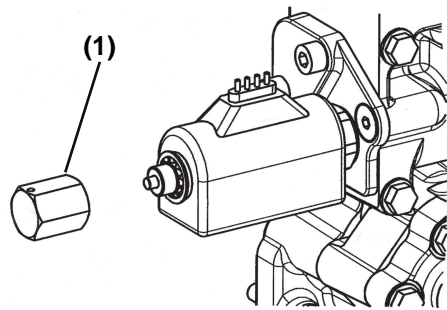
## Past Production Models



0001600A

**Figure 4**

1. With the engine(s) off, remove cap (**Figure 4, (1)**), nut (**Figure 4, (2)**) and collar (**Figure 4, (3)**). **CAUTION! If you have more than one engine, you cannot shift the marine gear into the "B" position after you install the "emergency nut."**



0001601A

**Figure 5**

2. Thread the emergency nut (**Figure 5, (1)**) onto electric valve. **WARNING! When you reverse the "emergency nut" the transmission is locked in gear and the boat will move as soon as you start the engine! There is no neutral safety protection in this mode. Make sure the area is clear before you start the engine.**

## TROLLING VALVES

There are three types of trolling valves available: mechanical and two types of electric trolling.

The trolling mode option allows the boat operator to slow the forward and aft speed of the boat for fishing.

Trolling mode is achieved by the ECU electronically adjusting the pressure bypass valves in the gearbox, allowing the clutches to slip. The trolling option (if equipped) is activated by putting the control lever in NEUTRAL and pressing the trolling switch or button located near the shift / throttle control head. Refer to the electronic control system manual for more information.

**NOTICE:** *The throttle lever does not override the trolling valve. The trolling function must be OFF before resuming normal travel speed.*

### Mechanical Trolling Valve

This trolling valve does not give feedback of fluctuations in the propeller speed.

### Shifting Pressure Adjustment

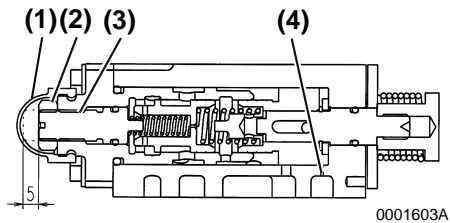


Figure 6

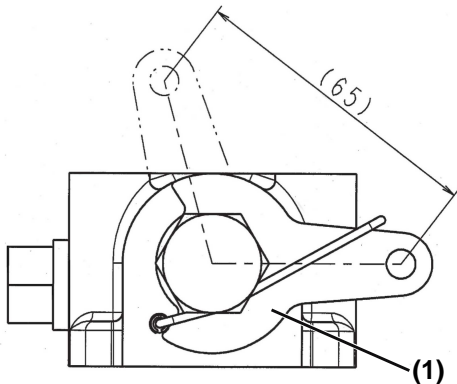


Figure 7

When the rubber cap (**Figure 6, (1)**) is removed, the lock nut (**Figure 6, (2)**) is loosened, and the adjustment screw (**Figure 6, (3)**) is rotated clockwise (tightened), the angle of a lever (**Figure 7, (1)**) lowers the shifting pressure and reduces the speed of the boat. **NOTICE:** *Use the trolling valve once daily. The orifice (**Figure 6, (4)**) can clog when the trolling valve is not used for extended periods of time, resulting in unexpected engagement of the valve.*

**Note:** When the trolling valve is not being used, secure it in place so that it does not move from vibration of the boat.

## OPTIONAL ACCESSORIES

### Electric Trolling Valve

The E-type trolling valve does not give feedback on fluctuations of the propeller speed.

The C-type trolling valve does give feedback on fluctuations of the propeller speed.

### Electric Trolling Valve Operation

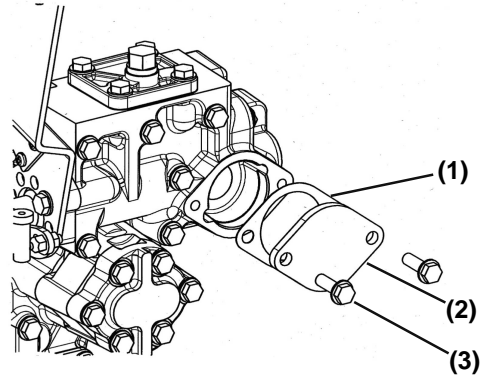
Refer to the electronic control system operation manual.

## PTO SPLINE SLEEVE AND FLANGE

### Specifications

Item	Specification
Spline Size	SAE Z=9, DP16/32, 30° Class I
Flange Size	SAE Type A
Permissible Input Torque	120 N·m (88.5 ft·lb)

### Installation of the PTO Spline Sleeve and Flange

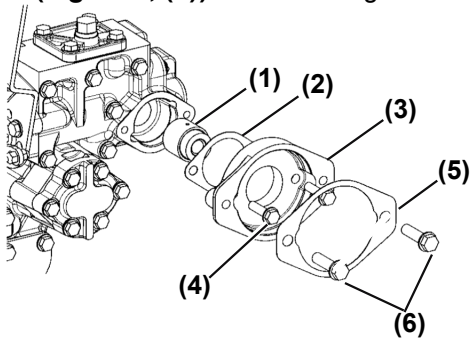


0001596A

**Figure 8**

1. Remove the PTO cover bolts (**Figure 8, (3)**).

- Remove the PTO cover (**Figure 8, (2)**) and gasket (**Figure 8, (1)**). Discard the gasket.



0001605A

**Figure 9**

- Insert the spline sleeve (**Figure 9, (1)**) into the input shaft.
- Use a new gasket (**Figure 9, (2)**), position the PTO flange (**Figure 9, (3)**). Tighten the bolts (**Figure 9, (4)**) to specified torque. See *Standard Torque Values on page 23*.
- Install the PTO device with M10×35 bolts (**43, (6)**).

**NOTICE:** *NEVER operate the marine gear without a PTO device or cover plate installed. Operating the marine gear without a PTO device or cover plate installed will cause marine gear oil to leak out.*

**This Page Intentionally Left Blank**