



YANMAR[®]

6SY **series**

OPERATION MANUAL

P/N: 0ASYM-G00101

**MARINE
ENGINE**

Disclaimers:

We reserve the right to change specifications and to improve our products without notice or obligation.

All information, illustrations and specifications in this manual are based on the latest information available at the time of publishing. The illustrations used in this manual are intended as representative reference views only. Moreover, because of our continuous product improvement policy, we may modify information, illustrations and / or specifications to explain and / or exemplify a product, service or maintenance improvement. We reserve the right to make any change at any time without notice. Yanmar and **YANMAR** are registered trademarks of Yanmar Co., Ltd. in Japan, the United States and / or other countries.

All Rights Reserved:

No part of this publication may be reproduced or used in any form by any means - graphic, electronic, or mechanical, including photocopying, recording, taping, or information storage and retrieval systems - without the written permission of Yanmar Marine International.

© 2006 Yanmar Marine International

1006

INTRODUCTION

Welcome to the world of Yanmar Marine! Yanmar Marine offers engines, drive systems and accessories for all types of boats, from runabouts to sailboats, and from cruisers to mega yachts. In marine leisure boating, the worldwide reputation of Yanmar Marine is second to none. We design our engines to respect nature. This means quieter engines, with minimal vibrations, cleaner than ever. All of our engines designed after 1996 meet most of the present and future emission regulations, such as BSO II, SAV, EPA II, IMO and RCD.

To help you enjoy your Yanmar 6SY engine for many years to come, please follow these recommendations:

- Read and understand this *Operation Manual* before you operate the machine to ensure that you follow safe operating practices and maintenance procedures.
- Keep this *Operation Manual* in a convenient place for easy access.
- If this *Operation Manual* is lost or damaged, order a new one from your authorized Yanmar marine dealer or distributor.
- Make sure this manual is transferred to subsequent owners. This manual should be considered a permanent part of the engine and remain with it.
- Constant efforts are made to improve the quality and performance of Yanmar products, so some details included in this *Operation Manual* may differ slightly from your engine. If you have any questions about these differences, please contact your authorized Yanmar marine dealer or distributor.
- The specifications and components (instrument panel, fuel tank, etc.) described in this manual may differ from ones installed on your vessel. Please refer to the manual provided by the manufacturer of these components.

INTRODUCTION

RECORD OF OWNERSHIP

Take a few moments to record the information you need when you contact Yanmar for service, parts or literature.

Engine Model: _____

Engine Serial No.: _____

Date Purchased: _____

Dealer: _____

Dealer Phone: _____

TABLE OF CONTENTS

	Page
Safety	1
Safety Precautions	2
General Information	2
Before You Operate	2
During Operation and Maintenance	2
Safety Decals	7
Product Overview	9
Yanmar 6SY Features and Applications	9
Component Identification	10
Nameplate	12
Engine Nameplate (Typical)	12
Function of Major Components	13
Engine Management System (EMS S6)	14
Positions of Sensors for EMS with S6	14
Rotation Speeds	15
Redundant Throttle Mode	15
Coolant Temperature	15
Oil Pressure	15
Before You Operate	17
Diesel Fuel	17
Diesel Fuel Specifications	17
Filling the Fuel Tank	18
Bleeding the Fuel System	19
Engine Oil	20
Engine Oil Specifications	20
Engine Oil Viscosity	20
Checking the Engine Oil	21
Adding Engine Oil	21
Selection of Marine Gear Oil	21

TABLE OF CONTENTS

Engine Coolant	22
Engine Coolant Specifications	22
Coolant (Closed Cooling System)	22
Checking the Coolant Level	22
Daily Checks	23
Visual Checks	23
Check for Fuel, Engine Oil and Engine Coolant Leaks	24
Check Diesel Fuel, Engine Oil and Engine Coolant Levels	24
Checking and Refilling Marine Gear Oil	24
Checking the Battery Charge	24
Cleaning the Battery	25
Checking the Battery Electrolyte Level	25
Checking the Alternator Belt	25
Checking the Alarm Indicators	25
Preparing Fuel, Oil and Coolant in Reserve	25
Engine Operation	27
Starting the Engine	29
Starting at Low Temperatures	29
Shutting Down the Engine	30
Checking the Engine After Operation	30
Periodic Maintenance	31
Safety Precautions	31
Precautions	33
The Importance of Periodic Maintenance	33
Performing Periodic Maintenance	33
The Importance of Daily Checks	33
Keep a Log of Engine Hours and Daily Checks	33
Yanmar Replacement Parts	33
Tools Required	33
Tightening Fasteners	33
Ask Your Authorized Yanmar Marine Dealer or Distributor For Help	33
Required EPA Maintenance USA Only	34
EPA Requirements USA Only	34
EPA Requirements	34
Conditions to Ensure Compliance with EPA Emission Standards	34
Inspection and Maintenance	35
Periodic Maintenance Schedule	35
Engines with Low Operating Hours	36

Inspection and Maintenance for EPA Emission- Related Parts	39
Maintenance Procedures	40
After Initial 50 Hours of Operation	40
Every 50 Hours of Operation	46
Every 250 Hours of Operation	47
Every 500 Hours of Operation	56
Every 1000 Hours of Operation	57
Every 2000 Hours of Operation	58
Long-Term Storage	59
Prepare Engine for Long-Term Storage	59
Specifications	61
Principal Engine Specifications	61
EPA Warranty USA Only	63
Yanmar Co., Ltd. Limited Emission Control System Warranty - USA Only	63
Your Warranty Rights and Obligations:	63
Warranty Period:	63
Warranty Coverage:	64
Exclusions:	64
Owner's Responsibility:	64
Customer Assistance:	64

This Page Intentionally Left Blank

SAFETY

Yanmar considers safety of great importance and recommends that anyone that comes into close contact with its products, such as those who install, operate, maintain or service Yanmar products exercise care, common sense and comply with the safety information in this manual and on the machine's safety decals. Keep the decals from becoming dirty or torn and replace them if they are lost or damaged. Also, if you need to replace a part that has a decal attached to it, make sure you order the new part and decal at the same time.



This safety alert symbol appears with most safety statements. It means attention, become alert, your safety is involved! Please read and abide by the message that follows the safety alert symbol.

DANGER

Indicates a hazardous situation which, if not avoided, *will* result in death or serious injury.

WARNING

Indicates a hazardous situation which, if not avoided, *could* result in death or serious injury.

CAUTION

Indicates a hazardous situation which, if not avoided, *could* result in minor or moderate injury.

NOTICE

Indicates a situation which can cause damage to the machine, personal property and / or the environment or cause the equipment to operate improperly.

SAFETY PRECAUTIONS

General Information

There is no substitute for common sense and careful practices. Improper practices or carelessness can cause burns, cuts, mutilation, asphyxiation, other bodily injury or death. This information contains general safety precautions and guidelines that must be followed to reduce risk to personal safety. Special safety precautions are listed in specific procedures. Read and understand all of the safety precautions before operation or performing repairs or maintenance.

Before You Operate

DANGER

The safety messages that follow have **WARNING** level hazards.



NEVER permit anyone to install or operate the engine without proper training.

- Read and understand this Operation Manual before you operate or service the engine to ensure that you follow safe operating practices and maintenance procedures.
- Safety signs and decals are additional reminders for safe operating and maintenance techniques.
- See your authorized Yanmar marine dealer or distributor for additional training.

During Operation and Maintenance

DANGER

The safety message that follows has **DANGER** level hazards.

Crush Hazard



NEVER stand under hoisted engine. If the hoist mechanism fails, the engine will fall on you.

⚠ WARNING

The safety messages that follow have **WARNING** level hazards.

Explosion Hazard

Avoid serious personal injury or equipment damage. While the engine is running or the battery is charging, hydrogen gas is being produced and can be easily ignited. Keep the area around the battery well-ventilated and keep sparks, open flames and any other form of ignition out of the area.

Fire and Explosion Hazard

Diesel fuel is flammable and explosive under certain conditions.

NEVER use a shop rag to catch the fuel.

Wipe up all spills immediately.

NEVER refuel with the engine running.

Store any containers containing fuel in a well-ventilated area, away from any combustibles or sources of ignition.

NEVER place diesel fuel or other flammable material such as oil, hay or dried grass close to the engine during engine operation or shortly after shut down.

Fire Hazard

Avoid injury or equipment damage from fire. Undersized wiring systems can cause an electrical fire.

Sever Hazard

Rotating parts can cause severe injury or death. NEVER wear jewelry, unbuttoned cuffs, ties or loose fitting clothing and ALWAYS tie long hair back when working near moving / rotating parts such as the flywheel or PTO shaft. Keep hands, feet and tools away from all moving parts.

Alcohol and Drug Hazard

NEVER operate the engine while under the influence of alcohol or drugs or feeling ill.

Exposure Hazard

To avoid injury, ALWAYS wear personal protective equipment including appropriate clothing, gloves, work shoes, eye and hearing protection as required by the task at hand.

WARNING

Entanglement Hazard



NEVER leave the key in the key switch when you are servicing the engine. Someone may accidentally start the engine and not realize you are servicing it.

Avoid personal injury. NEVER operate the engine while wearing a headset to listen to music or radio because it will be difficult to hear the warning signals.

Stop the engine before you begin to service it.

If you must service the engine while it is operating, remove all jewelry, tie back long hair, and keep your hands, other body parts and clothing away from moving / rotating parts.

Piercing Hazard



Avoid skin contact with high pressure diesel fuel spray caused by a fuel system leak such as a broken fuel injection line. High pressure fuel can penetrate your skin and result in serious injury. If you are exposed to high pressure fuel spray, obtain prompt medical treatment.

NEVER check for a fuel leak with your hands. ALWAYS use a piece of wood or cardboard. Have your authorized Yanmar marine dealer or distributor repair the damage.

Avoid skin contact with high pressure hydraulic fluid spray caused by a system leak. High pressure hydraulic fluid can penetrate your skin and result in serious injury. If you are exposed to high pressure hydraulic fluid spray, obtain prompt medical treatment.



Burn Hazard

Avoid serious injury. Some of the engine surfaces become very hot during operation and shortly after shut-down. Keep hands and other body parts away from hot engine surfaces.

Sudden Movement Hazard

Avoid personal injury. ALWAYS stop the engine before beginning service.

Exhaust Hazard



Avoid serious injury or death. NEVER block windows, vents or other means of ventilation if the engine is operating in an enclosed area. All internal combustion engines create carbon monoxide gas during operation and special precautions are required to avoid carbon monoxide poisoning.

⚠ CAUTION

The safety messages that follow have **CAUTION** level hazards.

Poor Lighting Hazard

Avoid personal injury or equipment damage. Ensure that the work area is adequately illuminated. **ALWAYS** install wire cages on portable safety lamps.

Tool Hazard

Avoid personal injury or equipment damage. **ALWAYS** use tools appropriate for the task at hand and use the correct size tool for loosening or tightening machine parts.

Flying Object Hazard

Avoid personal injury. **ALWAYS** wear eye protection when servicing the engine or when using compressed air or high-pressure water. Dust, flying debris, compressed air, pressurized water or steam may injure your eyes.

Coolant Hazard

Wear eye protection and rubber gloves when you handle Long Life engine coolant. If contact with the eyes or skin should occur, flush eyes and wash immediately with clean water.

NOTICE

The safety messages that follow have **NOTICE** level hazards.

It is important to perform daily checks as listed in the *Operation Manual*. Periodic maintenance prevents unexpected downtime, reduces the number of accidents due to poor engine performance and helps extend the life of the engine.

See your authorized Yanmar marine dealer or distributor if you need to operate the engine at high altitudes. At high altitudes the engine will lose power, run rough and produce exhaust gases that exceed the design specifications.



ALWAYS be environmentally responsible.

Follow the guidelines of the EPA or other governmental agencies for the proper disposal of hazardous materials such as engine oil, diesel fuel and engine coolant. Consult the local authorities or reclamation facility.

NEVER dispose of hazardous materials by dumping them into a sewer, on the ground or into ground water or waterways.

If a Yanmar Marine Engine is installed at an angle that exceeds the specifications stated in the Yanmar Marine Installation manuals, engine oil may enter the combustion chamber causing excessive engine speed, white exhaust smoke and serious engine damage. This applies to engines that run continuously or those that run for short periods of time.

NOTICE

If you have an installation with two or three engines and only one engine is operating, the water pickup (thru-hull) of the non-running engine(s) should be closed. This will prevent water from being forced past the seawater pump and eventually finding its way into the engine. The result of water entering the engine could cause seizure or other serious problems.

If you have an installation with two or three engines and only one engine is operating, please note that if the propeller shaft thru-hull (stuffing box) is lubricated by engine water pressure and the engines are interconnected, care must be taken that water from the running engine does not enter the exhaust of the non-running engine (s). This water could cause seizure of the non-running engine(s). See your authorized Yanmar marine dealer or distributor for a complete explanation of this condition.

If you have an installation with two or three engines and only one engine is operating, it is important to limit the amount of throttle applied to the running engine. If you observe black smoke or movement of the throttle does not increase engine rpm, you are overloading the engine that is running. Immediately throttle back to approximately 2/3 throttle or to a setting where the engine performs normally. Failure to do so may cause the running engine to overheat or cause excess carbon buildup which may shorten the engine's life.

SAFETY DECALS

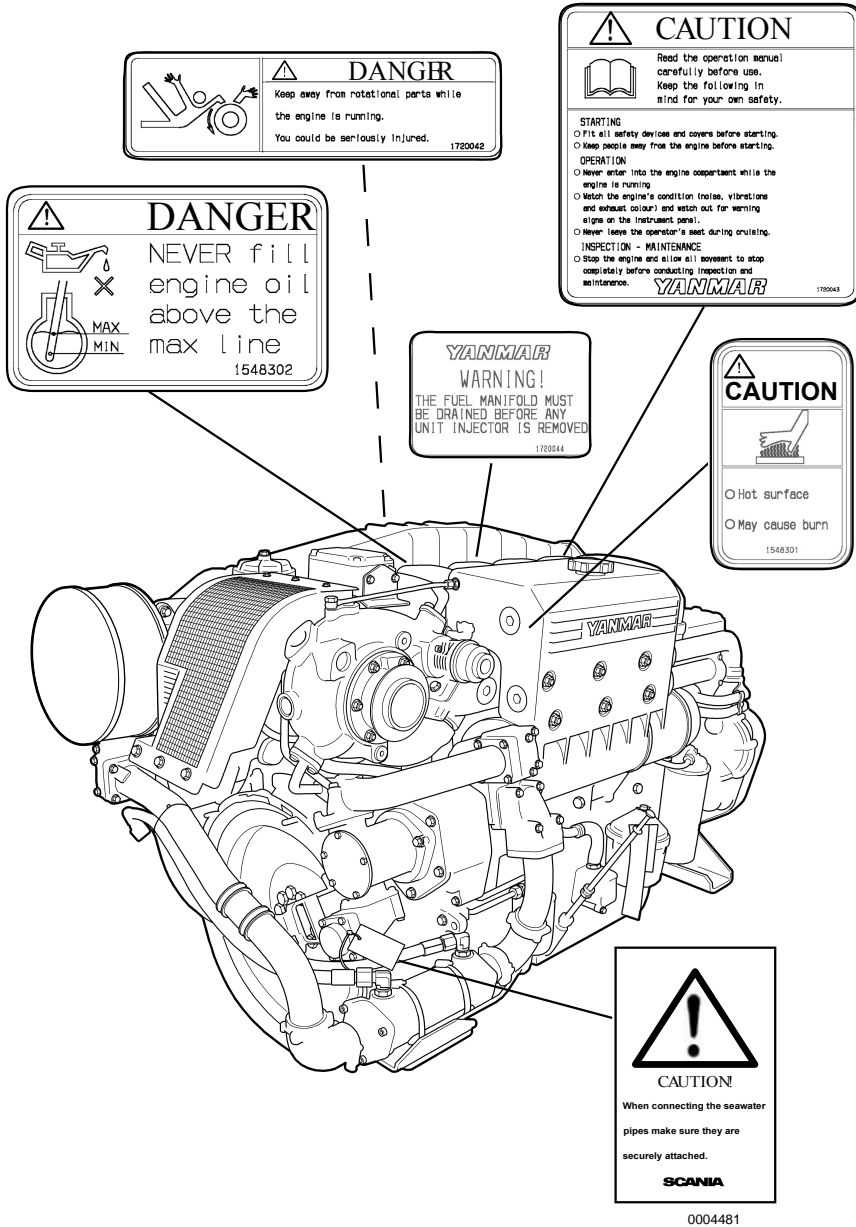

Figure 1

This Page Intentionally Left Blank

PRODUCT OVERVIEW

YANMAR 6SY FEATURES AND APPLICATIONS

The 6SY is a four-stroke, six-cylinder direct injection diesel engine. The engine is turbocharged and equipped with a charge air cooler containing a liquid cooling system.

The engine has a heat exchanger which is cooled by a seawater coolant system.

The engine is designed for pleasure craft use.

In order to obtain full performance from your engine, it is imperative that you check the size and structure of the hull and use a propeller of the appropriate size. As new boats are used, owners add additional equipment and completely fill the fuel and water tanks adding to the overall displacement (weight) of the vessel. Extra canvas enclosures, bottom paint, and bottom fouling can add additional hull resistance. It is recommended that a new vessel be propped so the engine can operate at 100 rpm above maximum rpm to allow for some added weight and hull resistance. Failure to do so can lead to reduced vessel performance, increased smoke levels and cause permanent damage to your engine.

The engine must be installed correctly with coolant lines, exhaust gas lines and electrical wiring. Any auxiliary equipment attached to the engine should be easy to use and accessible for service. To handle the drive equipment, propulsion systems (including the propeller) and other on-board equipment, always observe the instructions and cautions given in the operation manuals supplied by the shipyard and equipment manufacturers.

The laws of some countries may require hull and engine inspections, depending on the use, size and cruising area of the boat. The installation, fitting and surveying of this engine all require specialized knowledge and engineering skills. See Yanmar's local subsidiary in your region or your authorized Yanmar marine dealer or distributor.

COMPONENT IDENTIFICATION

Figure 1 illustrates a typical version of a 6SY engine. Your engine may have different equipment from that illustrated.

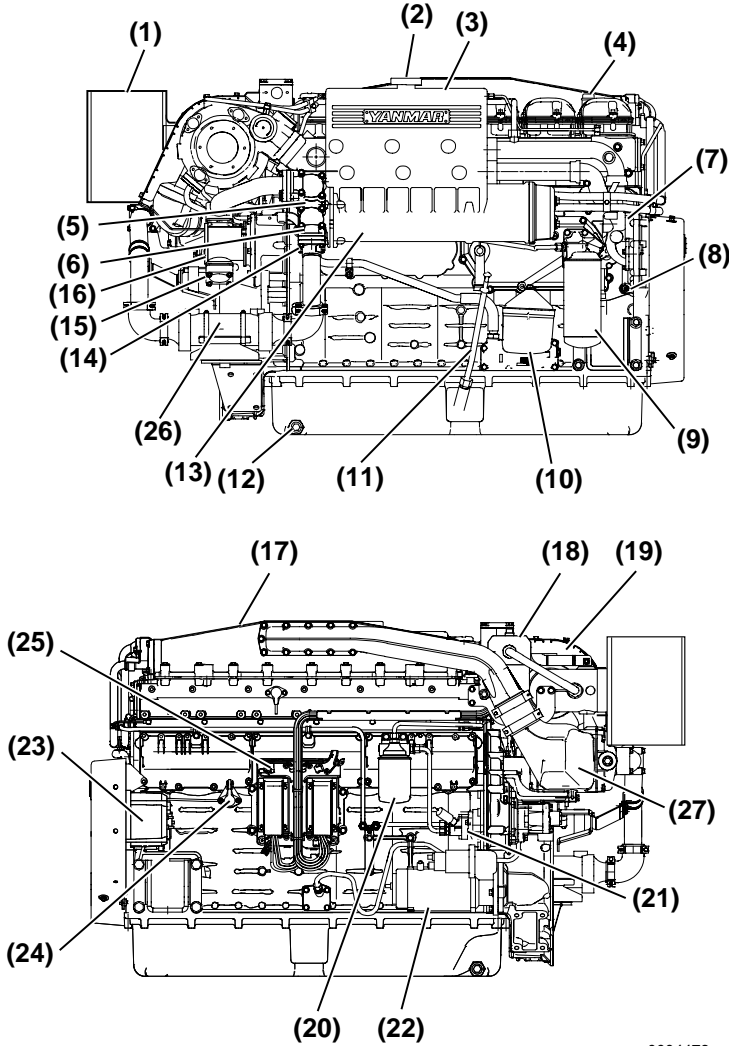

0004473

Figure 1

- | | |
|--|--|
| 1 – Air Filter | 15 – Seawater Inlet |
| 2 – Coolant Filler Cap | 16 – Seawater Pump |
| 3 – Coolant Recovery Tank | 17 – Charge Air Cooler |
| 4 – Engine Oil Filler Cap | 18 – Closed Crankcase Ventilation Filter |
| 5 – Engine Number, Stamped into the Engine Block | 19 – Turbocharger (Water-Cooled) |
| 6 – Nameplate | 20 – Fuel Filter |
| 7 – Coolant Pump | 21 – Fuel Pump |
| 8 – Coolant Drain | 22 – Starter Motor |
| 9 – Engine Oil Filter | 23 – Alternator (1 Standard, 2nd Optional) |
| 10 – Engine Oil Cleaner | 24 – Engine Oil Pressure Sensor |
| 11 – Engine Oil Dipstick | 25 – Control Unit (EMS S6) |
| 12 – Engine Oil Drain | 26 – Marine Gear Oil Cooler |
| 13 – Heat Exchanger | 27 – Charge Air Cooler |
| 14 – Seawater Outlet | |

NAMEPLATE

Figure 2 shows the location of regulatory information on Yanmar 6SY marine engines.

Engine Nameplate (Typical)

6SY Engines

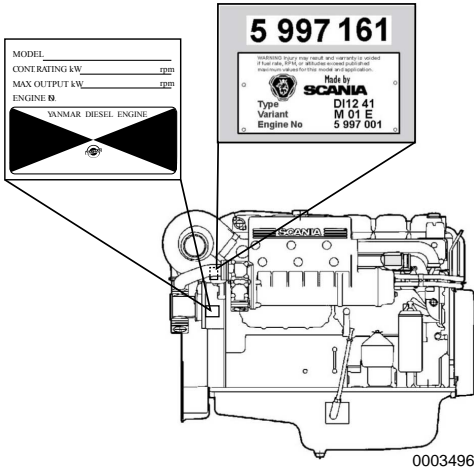

Figure 2

FUNCTION OF MAJOR COMPONENTS

Name of part	Function
Fuel Filter	Removes dirt and water from the fuel. Drain the filter periodically. The filter element should be replaced periodically. <i>See Draining or Replacing the Fuel Filter Element and Fuel Filter / Water Separator on page 40.</i>
Fuel Feed Pump	Pumps fuel from the tank to the fuel injection system.
Engine Oil Fill Port	Fill port for engine oil.
Engine Oil Filter	Filters fine metal fragments and carbon from the engine oil. Filtered engine oil is distributed to the engine's moving parts.
Coolant System	There are two coolant systems: closed cooling with coolant and seawater. The engine's combustion heat is cooled by the closed cooling circuit. The closed circuit is cooled by seawater using a heat exchanger. The seawater also cools the engine / marine gear oil.
Heat Exchanger	The heat exchanger cools the closed cooling circuit with seawater.
Closed Cooling Circulation Pump	The centrifugal water pump circulates coolant inside the engine. The circulating pump is driven by a belt.
Seawater Pump	The rubber impeller-type pump pumps seawater for cooling. Never operate it without seawater, as this will damage the impeller.
Coolant Filler Cap	The filler cap on the coolant tank has a pressure regulating valve. When the coolant temperature rises, the pressure rises inside the fresh water system.
Coolant Recovery Tank	The pressure regulating valve releases vapor and hot water overflow to the coolant recovery tank. When the engine stops and the coolant cools, the pressure in the coolant tank drops. The filler cap valve then opens to send water back from the coolant recovery tank. This minimizes coolant consumption. The closed cooling system coolant level can easily be checked and refilled in this tank.
Oil Cooler	A heat exchanger that cools high temperature engine oil using seawater.
Turbocharger	The turbocharger pressurizes the air coming into the engine. It is driven by a turbine that is energized by exhaust gases.
Anode	The metal area of the seawater coolant system is prone to electrical corrosion. The anodes are installed to prevent this corrosion. The anodes are reduced over time by electrical corrosion and must be replaced before it is completely consumed in order to ensure that the metal area of the seawater coolant system remains fully protected.
Nameplates	Nameplates are provided on the engine and the marine gear and have the model, serial number and other data.
Starter	Starter motor for the engine. Powered by the battery.
Alternator	Driven by belt and generates electricity and charges the battery.

PRODUCT OVERVIEW

ENGINE MANAGEMENT SYSTEM (EMS S6)

This engine has an Electronic Management System (EMS) with unit injectors which provide each cylinder with the right amount of fuel at the right time in all operating situations.

The EMS system consists of a control unit (S6) and sensors for speed, charge air temperature and pressure, coolant temperature, oil pressure and throttle actuation. These sensors constantly send signals to the control unit. With this input data and the programmed control software, the correct fuel amount and correct injection time are calculated for each unit injector under the specific operating conditions.

The EMS system sensors are also used to send signals to the digital display in the instrument panel.

The control unit constantly checks the sensors to make sure they are operational.

The control unit contains monitoring functions to protect the engine in the event of a fault which would otherwise damage it. In the event of a fault, an alarm for low oil pressure or high coolant temperature for example, the S6 control unit sends a message to the digital display.

Only authorized personnel are allowed to carry out diagnostic procedures and program changes.

The positions of the sensors which send signals to the control unit are shown (**Figure 3**).

Positions of Sensors for EMS with S6

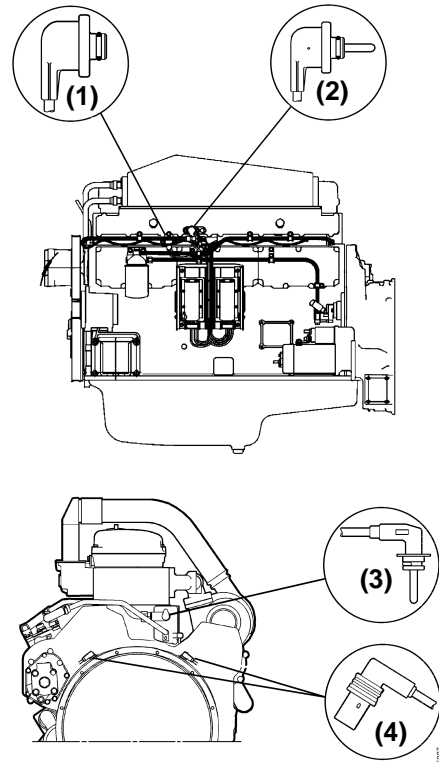

Figure 3

- 1 – Oil Pressure Sensor**
- 2 – Charge Air Temperature and Pressure Sensor**
- 3 – Coolant Temperature Sensor**
- 4 – Engine Speed Sensors (2 used)**

Rotation Speeds

Check instruments at regular intervals.

Rotation Speed	
0 - 500 rpm	Prohibited engine speed, passed through when stopping and starting.
500 - 700 rpm	Low idle. Engine idling is controlled by the EMS / S6 control system.
700 - 2300 rpm	Normal operating speed. The engine operating speed range is controlled by the EMS / S6 control system.
2400 - 2600 rpm	Unsuitable operating speed.
2600 - 3000 rpm	Prohibited engine speed.

Redundant Throttle Mode

If there is a fault with the normal throttle or if CAN communication is interrupted, a redundant throttle system is provided.

In the event of a CAN open circuit or throttle fault:

- The EMS automatically switches to the redundant throttle located on the key switch panel.
- The redundant throttle must be set at zero to be activated.
- A light will illuminate on the panel indicating the redundant throttle is activated.

Coolant Temperature

Normal coolant temperature when the engine is running is 70° to 90°C (158° to 194°F).

The EMS / S6 control system has the following alarm levels:

- If the temperature is high, 98° to 103°C, (208° to 217°F) for one second, the S6 control will send a CAN message which activates a warning.
- If the temperature exceeds 103°C (217°F), a warning is activated.
- A fault code is generated in the control unit.

After an alarm, approved values must be registered for more than two seconds before resetting the alarm.

NOTICE: *Excessively high coolant temperature can damage the engine.*

If running for extended periods under an extremely light load, the engine may have difficulty in maintaining normal operating temperature. However, the temperature will rise to a normal level again when the load on the engine is increased.

Oil Pressure

The EMS has the following alarm levels:

- At a speed of less than 1000 rpm and an oil pressure of less than 1.0 bar (15 psi)
- At a speed of more than 1000 rpm and an oil pressure of less than 2.3 bar (33 psi) for longer than five seconds

The following functions are available if there is an alarm:

- Alarm which only switches on a warning.
- Alarm which switches on a warning and reduces the power if this function is activated (maximum available is 70% of full power).
- A fault code is generated in the control unit.

After an alarm, approved values must be registered for more than two seconds before resetting the alarm.

This Page Intentionally Left Blank

BEFORE YOU OPERATE

This section of the *Operation Manual* describes the diesel fuel, engine oil, and engine coolant specifications and how to replenish them. It also describes the daily engine checkout.

DIESEL FUEL

Diesel Fuel Specifications

Diesel fuel should comply with the following specifications. The table lists several worldwide specifications for diesel fuels.

DIESEL FUEL SPECIFICATION	LOCATION
No. 2-D, No. 1-D, ASTM D975-94	USA
EN590:96	European Union
ISO 8217 DMX	International
BS 2869-A1 or A2	United Kingdom
JIS K2204 Grade No.2	Japan

BEFORE YOU OPERATE

Additional Technical Fuel Requirements

- The fuel cetane number should be equal to 45 or higher.
- The sulfur content must not exceed 0.5% by volume. Less than 0.05% is preferred.
- NEVER mix kerosene, used engine oil or residual fuels with the diesel fuel.
- Water and sediment in the fuel should not exceed 0.05% by volume.
- Keep the fuel tank and fuel-handling equipment clean at all times.
- Poor-quality fuel can reduce engine performance and / or cause engine damage.
- Fuel additives are not recommended. Some fuel additives may cause poor engine performance. See your authorized Yanmar marine dealer or distributor for more information.
- Ash content not to exceed 0.01% by volume.
- Carbon residue content not to exceed 0.35% by volume. Less than 0.1% is preferred.
- Total aromatics content should not exceed 35% by volume. Less than 30% is preferred.
- PAH (polycyclic aromatic hydrocarbons) content should be below 10% by volume.

Diesel Fuel Lines

Install the lines between the fuel tank and the fuel injection pump.

Be sure to install a drain cock (**Figure 1, (6)**) at the bottom of the fuel tank to remove water and contaminants.

Install a fuel filter / water separator (**Figure 1, (3)**) and a fuel filter between the fuel tank and the fuel injection pump.

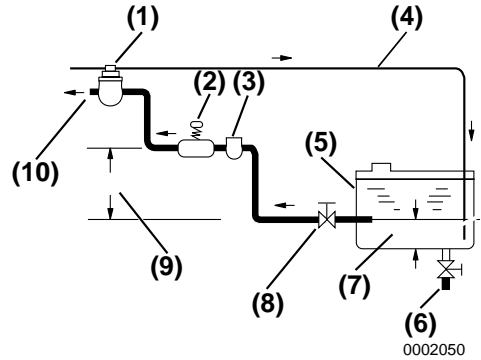

Figure 1

- 1 – Fuel Filter
- 2 – Fuel Priming Pump
- 3 – Fuel Filter / Water Separator
- 4 – Fuel Return Line
- 5 – Fuel Tank
- 6 – Fuel Tank Drain Cock
- 7 – Approximately 50 mm (1.96 in.)
- 8 – Fuel Shutoff Valve
- 9 – Less than 500 mm (19.68 in.)
- 10 – To Fuel Injection Pump

Filling the Fuel Tank

WARNING! Hold the hose nozzle firmly against the filler port while filling. This prevents static electricity buildup which could cause sparks and ignite fuel vapors. NEVER place diesel fuel or other flammable material such as oil, hay or dried grass close to the engine during engine operation or shortly after shut-down.

NOTICE: Only use diesel fuels recommended by Yanmar for the best engine performance, to prevent engine damage and to comply with EPA warranty requirements. Only use clean diesel fuel.

1. Clean the area around the fuel cap.
WARNING! Only fill the fuel tank with diesel fuel. Filling the fuel tank with gasoline may result in a fire and will damage the engine.

2. Remove the fuel cap from the fuel tank.
WARNING! Wipe up all spills immediately. Keep sparks, open flames or any other form of ignition (match, cigarette, static electric source) far away when refueling.
3. Stop fueling when the gauge shows the fuel tank is full. NOTICE: *NEVER overfill the fuel tank.*
4. Replace the fuel cap and hand-tighten. Over-tightening the fuel cap will damage it. **WARNING! Store any containers containing fuel in a well-ventilated area, away from any combustibles or sources of ignition.**
2. **WARNING! ALWAYS wear safety glasses when bleeding the fuel system.** Open the bleeder valve and operate the hand pump (Figure 2, (2)) until fuel flows without air bubbles. This may take 130 to 150 pump strokes.
3. Close the bleeder valve and remove the hose.
4. Continue hand pumping until there is resistance:
 - Approximately 20 strokes after replacing the fuel filter
 - Approximately 50 strokes after replacing a fuel injector
5. Start the engine and check for leaks. NOTICE: *NEVER hold the key in the START position for longer than 15 seconds or the starter motor will overheat.*

Bleeding the Fuel System

The fuel system needs to be bled under the following conditions:

- Before starting the engine for the first time.
- After running out of fuel and fuel has been added to the fuel tank.
- After fuel system maintenance, such as changing the fuel filter and draining the fuel filter / water separator, or replacing a fuel system component.

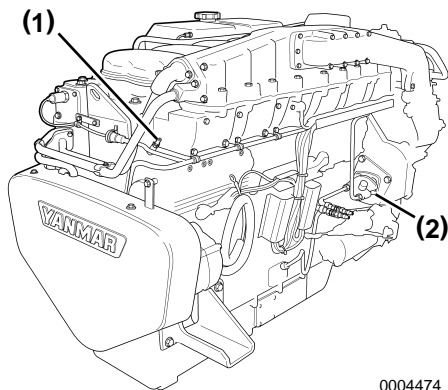

0004474

Figure 2

1. Install a transparent plastic hose on the fuel rail bleeder valve (Figure 2, (1)). Place the hose in an appropriate container.

If the engine fails to start after bleeding:

- Open the bleeder valve again and operate the hand pump until fuel without air bubbles flows out.
- Tighten the bleeder valve. Start the engine and check for leaks.

BEFORE YOU OPERATE

ENGINE OIL

Engine Oil Specifications

NOTICE: Only use the engine oil specified. Other engine oils may affect warranty coverage, cause internal engine components to seize, or shorten engine life. NEVER mix different types of engine oil. This may adversely affect the lubricating properties of the engine oil.

Use an engine oil that meets or exceeds the following guidelines and classifications:

Service Categories

- API Service Categories CH-4 and CI-4 or higher. TBN is 12 or higher.
- ACEA Service Categories E-3, E-4 or E-5
- JASO Service Category DH-1

Definitions

- API Classification (American Petroleum Institute)
- ACEA Classification (Association des Constructeurs Européens d'Automobiles)
- JASO (Japanese Automobile Standards Organization)

NOTICE: Be sure the engine oil, engine oil storage containers and engine oil filling equipment are free of sediment and water. Select the oil viscosity based on the ambient temperature where the engine is being operated. See the SAE Service Grade Viscosity Chart. Yanmar does not recommend the use of engine oil "additives."

Additional Technical Engine Oil Requirements:

The engine oil must be changed when the Total Base Number (TBN) has been reduced to 2.0. TBN (mgKOH/g) test method; JIS K-201-5.2-2 (HCl), ASTM D4739 (HCl).

Engine Oil Viscosity

Select the appropriate engine oil viscosity based on the ambient temperature shown in the SAE Service Grade Viscosity Chart (**Figure 3**).

SAE 15W40 is the recommended oil viscosity.

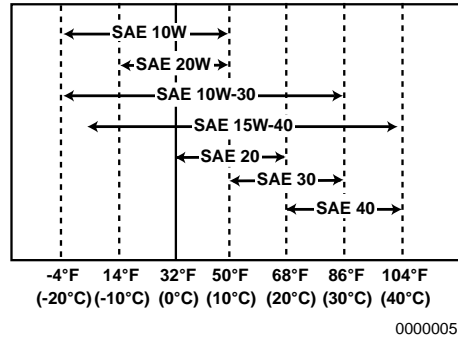
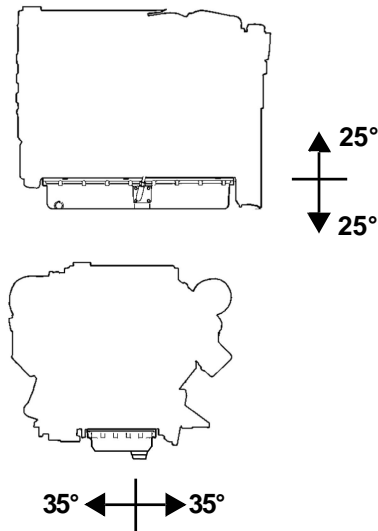

Figure 3

Maximum Angles of Inclination During Operation

Maximum permissible angles during operation vary, depending on the type of oil sump (**Figure 4**).

Note: The specified angle may only occur intermittently.



0004382

Figure 4

Checking the Engine Oil

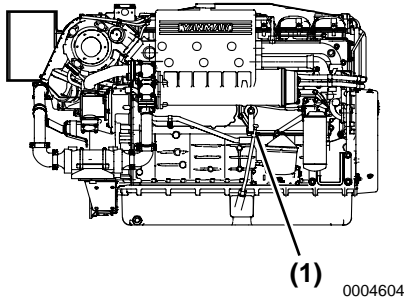

Figure 5

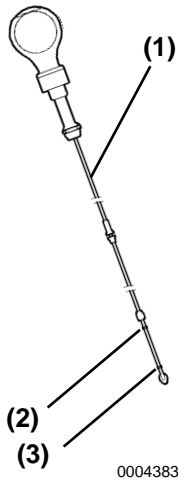

Figure 6

1. Remove dipstick (**Figure 6, (1)**) and (**Figure 5, (1)**) and wipe with clean cloth. *NOTICE: Prevent dirt and debris from contaminating the engine oil. Carefully clean the oil cap / dipstick and the surrounding area before you remove the cap.*
2. Fully reinsert dipstick.
3. Remove dipstick. The oil level should be between upper (**Figure 6, (2)**) and lower (**Figure 6, (3)**) lines on the dipstick.
4. Fully reinsert dipstick.

Adding Engine Oil

1. Remove the oil fill port cap and fill with engine oil.
2. Fill with oil to the upper limit (**Figure 6, (2)**) on the dipstick (**Figure 6, (1)**). Insert the dipstick fully to check the level. *NOTICE: NEVER overfill. Overfilling may result in white exhaust smoke, engine overspeed or internal damage. ALWAYS keep the oil level between upper and lower lines on the oil cap / dipstick.*
3. Tighten the fill port cap securely by hand.

Selection of Marine Gear Oil

Refer to the operation manual for the marine gear.

ENGINE COOLANT

Engine Coolant Specifications

Use a Long Life Coolant (LLC) that meets or exceeds the following guidelines and specifications: **NOTICE:** *Only use the engine coolant specified. Other engine coolants may affect warranty coverage, cause an internal buildup of rust and scale and / or shorten engine life. NEVER mix different types of engine coolants. This may adversely affect the properties of the engine coolant.*

- BASF G48 or D542, Glycol - 30% or higher
- ASTM D6210, D4985 (US)
- JIS K-2234 (Japan)
- SAE J814C, J1941, J1034 or J2036 (International)

Note: In the U.S., LLC is required for the warranty to be valid.

Coolant (Closed Cooling System)

NOTICE: *Always add LLC to soft water - especially when operating in cold weather. Without LLC, cooling performance will decrease due to scale and rust in the cooling system. Water alone may freeze and form ice; it expands approximately 9% in volume. Use the proper amount of coolant concentrate for the ambient temperature as specified by the LLC manufacturer. LLC concentration should be a minimum of 30% to a maximum of 60%. Too much LLC will also decrease the cooling efficiency. Do not mix different types or brands of LLC or a harmful sludge may form. Do not use hard water. Water should be clean and free from sludge or particles.*

Following the manufacturer's recommendations, use a proper LLC which will not have any adverse effects on the materials (cast iron, aluminum, copper, etc.) of the engine's fresh water cooling system. *See Engine Coolant Specifications on page 22.*

Replace engine coolant periodically, according to the maintenance schedule in this *Operation Manual*.

Remove scale from the cooling system periodically by flushing the system.

Checking the Coolant Level

1. Open the coolant recovery tank filler cap and check the coolant level.
WARNING! NEVER remove the coolant filler cap if the engine is hot. Steam and hot engine coolant will escape and seriously burn you. Allow the engine to cool sufficiently before attempting to remove the filler cap.
WARNING! Wear eye protection and rubber gloves when you handle Long Life engine coolant. If contact with the eyes or skin should occur, flush eyes and wash immediately with clean water.
2. The correct level for a cold engine is approximately 50 mm (2 in.) below the full line.
3. Add coolant as necessary. Do not add water. *See Engine Coolant on page 22.* **WARNING! Securely tighten the filler cap after checking the coolant level. Steam can escape during engine operation if the cap is loose.**

CAUTION! *When adding large amounts of coolant, NEVER pour cold coolant into a hot engine.* NOTICE: *Only use the engine coolant specified. Other engine coolants may affect warranty coverage, cause an internal buildup of rust and scale and / or shorten engine life. Prevent dirt and debris from contaminating engine coolant. Carefully clean the heat exchanger cap and the surrounding area before you remove the cap. NEVER mix different types of engine coolants. This may adversely affect the properties of the engine coolant.*

DAILY CHECKS

Before you head out for the day, make sure the Yanmar engine is in good operating condition. Make sure you check the following items.

Visual Checks

1. Check for damaged or missing parts.
2. Check for loose, missing or damaged fasteners.
3. Check the electrical harnesses for cracks, abrasions, and damaged or corroded connectors.
4. Check hoses for cracks, abrasions and damaged, loose or corroded clamps.
5. Check the fuel filter / water separator for presence of water and contaminants. If you find any water or contaminants, drain the fuel filter / water separator. *See Draining or Replacing the Fuel Filter / Water Separator on page 40.*
If you have to drain the fuel filter / water separator frequently, drain the fuel tank and check for the presence of water in your fuel supply. *See Draining the Fuel Tank on page 47 .*

NOTICE: *If any problem is noted during the visual check, the necessary corrective action should be taken before you operate the engine.*

BEFORE YOU OPERATE

Check for Fuel, Engine Oil and Engine Coolant Leaks

Visually check the engine for fuel, engine oil or engine coolant leakage. **WARNING! Avoid skin contact with high-pressure diesel fuel spray caused by a fuel system leak such as a broken fuel injection line. High-pressure fuel can penetrate your skin and result in serious injury. If you are exposed to high-pressure fuel spray, obtain prompt medical treatment. NEVER check for a fuel leak with your hands. ALWAYS use a piece of wood or cardboard. Have your authorized Yanmar marine dealer or distributor repair the damage.**

1. Start the engine.
2. Check for oil, coolant, fuel, air and exhaust leaks.
3. Tighten or replace leaking connections.

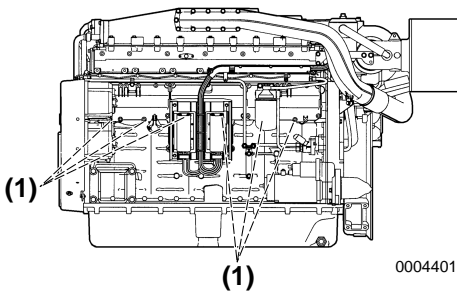

Figure 7

4. Check the overflow holes (**Figure 7, (1)**) in the block. Leakage from these holes indicates that the O-rings between the cylinder liners and the crankcase are leaking.
 - If coolant is running out, the O-ring is leaking.
 - If oil is running out, the liner shelf is leaking.
5. Check that there are no leaks from the coolant pump. If a leak occurs, replace the pump seal or the coolant pump assembly.

6. A small amount of leakage from the overflow holes during the engine break-in period is normal. Seals and O-rings must be lubricated with soap or oil when installed. This leakage normally stops after time.

Check Diesel Fuel, Engine Oil and Engine Coolant Levels

Follow the procedures in *Filling the Fuel Tank* on page 18, *Checking the Engine Oil* on page 21 and *Checking the Coolant Level* on page 22 to check these levels.

Checking and Refilling Marine Gear Oil

Refer to the operation manual for the marine gear.

Checking the Battery Charge

Measure the specific gravity of the battery with a hydrometer. **WARNING! Batteries contain sulfuric acid. NEVER allow battery fluid to come in contact with clothing, skin or eyes. Severe burns could result. ALWAYS wear safety glasses and protective clothing when servicing the battery. If battery fluid contacts the eyes and / or skin, immediately flush the affected area with a large amount of clean water and obtain prompt medical treatment.**

When the specific gravity of the fluid is 1.28 at 20°C (68°F), 1.294 at 0°C (32°F), 1.308 at -20°C (-4°F) the battery is fully charged. When the specific gravity is below 1.20, charge the battery.

A discharged battery will freeze at -5°C (23°F). If the specific gravity cannot be raised by charging, the battery must be replaced.

Do not rapid-charge the battery. Rapid-charging eventually results in damage to the battery.

Note: The capacities of the standard alternator and the recommended battery assume only the power necessary for regular operation. If the power is also used for lighting or other purposes, the generating and charging capacities may be insufficient. In such cases, see your authorized Yanmar marine dealer or distributor.

Maintenance-free batteries can be checked using a battery tester. See your authorized Yanmar marine dealer or distributor.

WARNING! Avoid injury or death due to explosion or fire. NEVER check the battery charge by shorting out the terminals. ALWAYS use a hydrometer to check the battery charge. Avoid serious injury. NEVER recharge a frozen battery. If the electrolyte is frozen, slowly warm the battery before recharging it.

Cleaning the Battery

WARNING! Turn off the battery switch (if equipped) or disconnect the negative battery cable before servicing the electrical system.

1. Clean batteries, cables and cable terminals. **WARNING! Batteries contain sulfuric acid. NEVER allow battery fluid to come in contact with clothing, skin or eyes. Severe burns could result. ALWAYS wear safety goggles and protective clothing when servicing the battery. If battery fluid comes into contact with the eyes and / or skin, immediately flush the affected area with a large amount of clean water and obtain prompt medical treatment.**
2. Check that all cable terminals are firmly tightened.

3. Apply petroleum jelly to battery terminal posts and cable terminals. **WARNING! Check the electrical harnesses for cracks, abrasions, and damaged or corroded connectors. ALWAYS keep the connectors and terminals clean.**

Checking the Battery Electrolyte Level

Be sure to check the battery electrolyte level before use. See *Checking the Battery Electrolyte Level (Serviceable Batteries Only)* on page 46.

Checking the Alternator Belt

Be sure to check the belt tension before use. See *Checking and Adjusting the Alternator Belt* on page 45.

Checking the Alarm Indicators

Check the instruments and alarm indicators at regular intervals.

Preparing Fuel, Oil and Coolant in Reserve

Prepare sufficient fuel for the day's operation. Always store engine oil and coolant in reserve (for at least one refill) on board, to be ready for emergencies.

This Page Intentionally Left Blank

ENGINE OPERATION

This section of the *Operation Manual* describes the procedures for starting the engine, checking engine performance during operation and shutting the engine down.

WARNING

Fire and Explosion Hazard



Avoid serious personal injury. NEVER jump start the engine. Sparks caused by shorting the battery to the starter terminals may cause a fire or explosion.

ONLY use the key switch to start the engine.

Diesel fuel is flammable and explosive under certain conditions. NEVER put diesel fuel or other flammable material such as oil, hay or dried grass near the engine during engine operation or shortly after shutdown.

Sudden Movement Hazard

Be sure the boat is in open water away from other boats, docks or other obstructions before increasing rpm.

Avoid unexpected equipment movement. Shift the marine gear into the NEUTRAL position any time the engine is at idle.

To prevent accidental equipment movement, NEVER start the engine in gear.

⚠ WARNING



Sever Hazard

Rotating parts can cause severe injury or death. **NEVER** operate the engine without the guards in place.

Before starting the engine, **ALWAYS** make sure that all bystanders are clear of the area.

Keep children and pets away while the engine is operating.

Exhaust Hazard



Avoid serious injury or death. **NEVER** block windows, vents or other means of ventilation if the engine is operating in an enclosed area. All internal

combustion engines create carbon monoxide gas during operation and special precautions are required to avoid carbon monoxide poisoning.

Piercing Hazard



Avoid injury from escaping fuel under pressure. **NEVER** check for a fuel leak with your hands. **ALWAYS** use a

piece of wood or cardboard.

⚠ CAUTION



Avoid serious personal injury or equipment damage. **ALWAYS** turn off the battery switch (if equipped) or disconnect

the negative battery cable before servicing the equipment.

NOTICE

If any indicator illuminates during engine operation, stop the engine immediately. Determine the cause and repair the problem before you continue to operate the engine.

Observe the following environmental operating conditions to maintain engine performance and avoid premature engine wear:

- Avoid operating in extremely dusty conditions.
- Avoid operating in the presence of chemical gases or fumes.
- NEVER run the engine if the ambient temperature is above +40°C (+104°F) or below -16°C (+5°F).
- If the ambient temperature exceeds +40°C (+104°F), the engine may overheat and cause the engine oil to break down.
- If the ambient temperature is below -16°C (+5°F), rubber components such as gaskets and seals will harden causing premature engine wear and damage.
- Contact your authorized Yanmar marine engine dealer or distributor if the engine will be operated outside of this standard temperature range.

NEVER engage the starter motor while the engine is running. Damage to the starter motor pinion and / or ring gear will result.

STARTING THE ENGINE

NOTICE: *If the vessel is equipped with a water lift (water lock) muffler, excessive cranking could cause seawater to enter the cylinders and damage the engine. If the engine does not start after cranking for 15 seconds, close the thru-hull water intake valve to avoid filling the muffler with water. Crank for 15 seconds or until the engine starts. When the engine starts, stop the engine immediately and press the switch to the OFF position.*

1. Open the seacock (if equipped).
2. Open the fuel tank cock.
3. Put transmission in neutral.
4. Turn the battery master switch (if equipped) ON.
5. Press the ENG ON switch (if equipped) or turn key switch to ON. **NOTICE:** *NEVER hold the key in the START position for longer than 15 seconds or the starter motor will overheat.*

Starting at Low Temperatures

Comply with local environmental requirements. Use engine heaters to avoid starting problems and white smoke. **NOTICE:** *NEVER use an engine starting aid such as ether. Engine damage will result.*

To limit white smoke, run the engine at low speed and under moderate load until the engine reaches normal operating temperature. A light load on a cold engine provides better combustion and faster engine warm-up than no load.

Avoid running the engine at idling speed any longer than necessary.

SHUTTING DOWN THE ENGINE

NOTICE: *For maximum engine life, Yanmar recommends that when shutting the engine down, you allow the engine to run, without load, for five minutes. This will allow the engine components that operate at high temperatures, such as the exhaust system, to cool slightly before the engine itself is shut down.*

1. Check to see that there are no active faults.
2. Push the OFF switch (if equipped) or turn the key switch to OFF. **NOTICE:** *NEVER use the emergency stop switch for a normal engine shutdown. Use this switch only when stopping the engine suddenly in an emergency.*
3. Turn the battery master switch (if equipped) OFF.
4. Close the fuel tank cock.
5. Close the seacock (if equipped). **NOTICE:** *ALWAYS close the seacock when you shut down the engine. Neglecting to close the seacock could allow water to leak into the boat and may cause it to sink.*

CHECKING THE ENGINE AFTER OPERATION

- Check that the key switch is in the OFF position and battery master switch (if equipped) is OFF.
- Fill the fuel tank. Make sure that the filler cap and the area around the fill opening are clean to avoid contamination of the fuel. *See Filling the Fuel Tank on page 18.*
- Turn off the inlet valve (seacock) for the seawater system (if equipped).
- If there is a risk of freezing, check that the closed coolant system contains enough coolant. *See Engine Coolant on page 22.*
- If there is a risk of freezing, empty the seawater system. *See Prepare Engine for Long-Term Storage on page 59.*
- At temperatures below 0°C (32°F), connect the engine heater (if equipped).

PERIODIC MAINTENANCE

SAFETY PRECAUTIONS

WARNING

Crush Hazard



If you need to transport an engine for repair have a helper assist you attach it to a hoist and load it on a truck.

Avoid personal injury or equipment damage. The engine lifting eyes are engineered to lift the weight of the marine engine only. ALWAYS use the engine lifting eyes when lifting the engine.

Avoid serious personal injury. Additional equipment is necessary to lift the marine engine and marine gear together. ALWAYS use lifting equipment with sufficient capacity to lift the marine engine.

Welding Hazard

Make welding repairs safely.

- ALWAYS turn off the battery switch (if equipped) or disconnect the negative battery cable and the leads to the alternator when welding on the equipment.
- Remove the multi-pin connector to the engine control unit. Connect the weld clamp to the component to be welded and as close as possible to the welding point.
- NEVER connect the weld clamp to the engine or in a manner which would allow current to pass through a mounting bracket.
- When welding is completed, reconnect the leads to the alternator and engine control unit prior to reconnecting the batteries.

Exhaust Hazard



Avoid serious injury or death. ALWAYS ensure that all connections are tightened to specifications after repair is made to the exhaust system.

All internal combustion engines create carbon monoxide gas during operation and special precautions are required to avoid carbon monoxide poisoning.

WARNING

Shock Hazard



Avoid serious personal injury or equipment damage. ALWAYS turn off the battery switch (if equipped) or disconnect

the negative battery cable before servicing the equipment.

Avoid personal injury or equipment damage. ALWAYS keep the electrical connectors and terminals clean. Check the electrical harnesses for cracks, abrasions, and damaged or corroded connectors.

NOTICE

Any part which is found defective as a result of inspection or any part whose measured value does not satisfy the standard or limit must be replaced.

Modifications may impair the engine's safety and performance characteristics and shorten the engine's life. Any alterations to this engine may void its warranty. Be sure to use Yanmar genuine replacement parts.

PRECAUTIONS

The Importance of Periodic Maintenance

Engine deterioration and wear occur in proportion to the length of time the engine has been in service and the conditions the engine is subjected to during operation. Periodic maintenance prevents unexpected downtime, reduces the number of accidents due to poor machine performance and helps extend the life of the engine.

Performing Periodic Maintenance

Perform periodic maintenance procedures in an open, level area free from traffic. If possible, perform the procedures indoors to prevent environmental conditions such as rain, wind, or snow, from damaging the engine. **WARNING! NEVER block windows, vents, or other means of ventilation if the engine is operating in an enclosed area. All internal combustion engines create carbon monoxide gas during operation. Accumulation of this gas within an enclosure could cause illness or even death.**

The Importance of Daily Checks

Periodic Maintenance Schedules assume that the daily checks are performed on a regular basis. Make it a habit of performing daily checks before the start of each operating day. See *Daily Checks* on page 23.

Keep a Log of Engine Hours and Daily Checks

Keep a log of the number of hours the engine has run each day and a log of the daily checks performed. Also note the date, type of repair (e.g., replaced alternator) and parts used for any service needed between the periodic maintenance intervals. Periodic maintenance intervals are every 50, 250, 500, 750, 1000 and 2000 engine hours. Failure to perform periodic maintenance will shorten the life of the engine.

Yanmar Replacement Parts

Yanmar recommends that you use genuine Yanmar parts when replacement parts are needed. Genuine replacement parts help ensure long engine life. **NOTICE: Only use replacement parts specified. Other replacement parts may affect warranty coverage, cause internal engine damage or shorten engine life.**

Tools Required

Before you start any periodic maintenance procedure make sure you have the tools you need to perform all of the required tasks.

Tightening Fasteners

Use the correct amount of torque when you tighten fasteners on the machine. Applying excessive torque may damage the fastener or component and not enough torque may cause a leak or component failure. **NOTICE: Always tighten to the specified torque. Loose parts can cause equipment damage or cause the engine to operate improperly.**

Ask Your Authorized Yanmar Marine Dealer or Distributor For Help

Our professional service technicians have the expertise and skills to help you with any maintenance or service related procedures.

PERIODIC MAINTENANCE

Required EPA Maintenance USA Only

To maintain optimum engine performance and compliance with the Environmental Protection Agency (EPA) Regulation Engines, it is essential that you follow the *Periodic Maintenance Schedule on page 35*.

EPA Requirements USA Only

The following are the installation requirements for the EPA. Unless these requirements are met, the exhaust gas emissions will not be within the limits specified by the EPA.

- Permissible value for intake negative pressure: 3.9 kPa (400 mmAq) or lower
- Permissible value for exhaust back pressure: 9.8 kPa (1000 mmAq) or lower

EPA REQUIREMENTS

The EPA emission regulation is applicable only in USA.

Conditions to Ensure Compliance with EPA Emission Standards

This product is an EPA-approved engine.

The following are the conditions that must be met in order to ensure that the emissions during operation meet the EPA standards. Be sure to follow these:

The operating conditions should be as follows:

- Ambient temperature: -20° to 40°C (-4° to 104°F)
- Relative humidity: 80% or lower
- Permissible value for intake negative pressure: 3.9 kPa (400 mmAq) or lower
- Permissible value for exhaust back pressure: 9.8 kPa (1000 mmAq) or lower

The fuel and lubricating oil used should be as follows:

- Diesel fuel oil: ASTM D975 No. 1-D or No. 2-D or equivalent (minimum of cetane No. 45)
- Lubricating oil: ACEA Class E3, E4 or E5; Type API, Class CH-4, CI-4

Be sure to perform inspections as outlined in *Inspection and Maintenance for EPA Emission-Related Parts on page 39* and keep a record of the results.

Pay particular attention to these important points:

- Replacing the engine oil
- Replacing the lube oil filter
- Replacing the fuel filter
- Cleaning the intake silencer (air cleaner)

Note: Inspections are divided into two sections in accordance with who is responsible for performing the inspection: the user or the maker.

Inspection and Maintenance

See *Inspection and Maintenance for EPA Emission-Related Parts* on page 39 for the EPA emission-related parts. Inspection and maintenance procedures not shown in the *Inspection and Maintenance for EPA Emission-Related Parts* on page 39 section are covered in *Periodic Maintenance Schedule* on page 35.

This maintenance must be performed to keep the emission values of your engine in the standard values during the warranty period. The warranty period is determined by the age of the engine or the number of hours of operation.

PERIODIC MAINTENANCE SCHEDULE

Daily and periodic maintenance is important to keep the engine in good operating condition. The following is a summary of maintenance items by periodic maintenance intervals. Periodic maintenance intervals vary depending on engine application, loads, diesel fuel and engine oil used and are hard to establish definitively. The following should be treated only as a general guideline.

CAUTION! Establish a periodic maintenance plan according to the engine application and make sure you perform the required periodic maintenance at intervals indicated. Failure to follow these guidelines will impair the engine's safety and performance characteristics, shorten the engine's life and may affect the warranty coverage on your engine. See your authorized Yanmar marine dealer or distributor for assistance when checking items marked with a ●.

Engines with Low Operating Hours

Run the engine until it reaches operating temperature and then perform the following maintenance procedures:

- Check the engine oil level. *See Checking the Engine Oil on page 21.*
- Check the coolant level. *See Checking the Coolant Level on page 22.*
- Check the low pressure indicator. *See Checking the Alarm Indicators on page 25.*
- Check the fuel level. *See Filling the Fuel Tank on page 18.*
- Check the battery electrolyte level. *See Checking the Battery Electrolyte Level (Serviceable Batteries Only) on page 46.*
- Clean the battery. *See Cleaning the Battery on page 25.*
- Check for any leakage, repair as necessary.

PERIODIC MAINTENANCE

○: Check or Clean ◇: Replace ●: Contact your authorized Yanmar marine dealer or distributor							
System	Item	Daily	Periodic Maintenance Interval				
			Every 50 hours or one month whichever comes first	Every 250 hours or one year whichever comes first	Every 500 hours or 2 years whichever comes first	Every 1000 hours or 4 years whichever comes first	Every 2000 hours or 8 years whichever comes first
Whole	Visual inspection of engine exterior	○					
Fuel System	Check the fuel level, and refill	○					
	Drain the fuel tank			○			
	Drain the fuel filter and the fuel / water separator		○ (Initial 50)				
	Replace the fuel filter element			◇			
	Check the unit injector/ rocker arms			● (Initial 250)		●*	
	Overhaul and check the fuel feed pump						●
	Replace the rubber fuel hoses	Replace every 2 years or every 2000 hours, whichever comes first.					
Lubricating System	Check the engine oil level	○					
	Change the engine oil		◇ (Initial 50)	◇			
	Replace the engine oil filter element		◇ (Initial 50)	◇			
	Replace the closed crankcase ventilation filter element			◇			
	Clean the centrifugal oil cleaner		○ (Initial 50)	○			
	Clean the engine oil cooler						●
Cooling System	Check the seawater outlet	○ During Operation					
	Check the coolant level	○					
	Check or replace the seawater pump impeller			○	◇		
	Change the engine coolant	Every year When long life coolant is used, replace every two years. See <i>Engine Coolant Specifications</i> on page 22.					
	Clean and check the seawater passages					●	
	Clean the seawater and engine cooling system						●
	Check or replace the anodes			◇			
	Clean the closed cooling system (internal)			○			
Air Intake and Exhaust System	Clean or replace the air intake filter element			○			
	Clean the exhaust/ water mixing elbow			●			

PERIODIC MAINTENANCE

○: Check or Clean ◇: Replace ●: Contact your authorized Yanmar marine dealer or distributor							
System	Item	Daily	Periodic Maintenance Interval				
			Every 50 hours or one month whichever comes first	Every 250 hours or one year whichever comes first	Every 500 hours or 2 years whichever comes first	Every 1000 hours or 4 years whichever comes first	Every 2000 hours or 8 years whichever comes first
	Clean the turbocharger			●*			
	Clean charge air cooler			●			
Electrical System	Check the alarm indicators	○					
	Check the battery charge	○					
	Clean the battery	○					
	Check battery electrolyte level		○				
	Adjust the tension of the alternator belt or replace belt		○ (Initial 50)		○	◇	
	Check the wiring connectors			○			●
Engine Cylinder Head and Block	Check for leakage of fuel, engine oil and engine coolant	○ After starting					
	Tighten all major nuts and bolts			●			
	Adjust the intake / exhaust valve clearance			● (Initial 250)		●	
Miscellaneous Items	Check the electronic control system (EMS) operation	○	○ (Initial 50)				
	Adjust the propeller shaft alignment		● (Initial 50)		●		
	Check or replace the flexible engine mounts			○		◇	

* Required to conform to U.S. EPA regulations. See *EPA Requirements USA Only* on page 34.

Note: These procedures are considered normal maintenance and are performed at the owner's expense.

Inspection and Maintenance for EPA Emission-Related Parts

Parts	Interval
Clean fuel injection nozzle	1500 hours
Check fuel injection nozzle pressure and spray pattern	3000 hours
Check fuel injection pump adjustment	
Check turbocharger adjustment (if equipped)	
Check electronic engine control unit (ECU) and its associated sensors and actuators	

Note: The inspection and maintenance items shown above to be performed at your Yanmar dealer or distributor.

MAINTENANCE PROCEDURES

After Initial 50 Hours of Operation

Perform the following maintenance after the initial 50 hours of operation.

- Draining the Fuel Filter and Fuel / Water Separator
- Changing Engine Oil and Replacing the Engine Oil Filter Element
- Cleaning the Centrifugal Oil Cleaner
- Checking and Adjusting Alternator Belt
- Checking Electronic Management System (EMS) Operation
- Adjusting Propeller Shaft Alignment

Draining or Replacing the Fuel Filter Element and Fuel Filter / Water Separator

Draining or Replacing the Fuel Filter Element

1. Close the fuel tank cock.

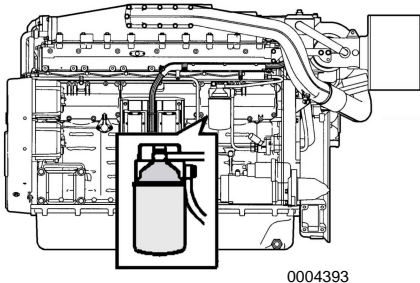

Figure 1

2. Loosen the drain plug. Drain off any water or dirt. **WARNING! NEVER use a shop rag to catch the fuel. Vapors from the rag are flammable and explosive. Wipe up any spills immediately.**

3. Clean the outside of the filter and remove it by turning it counterclockwise. **NOTICE: Put an approved container under the opening when removing any fuel system component to perform maintenance (such as changing the fuel filter). Dispose of waste properly.**
4. Install a new filter and hand-tighten.
5. Drain the fuel filter / water separator. See *Draining or Replacing the Fuel Filter / Water Separator* on page 40.

Draining or Replacing the Fuel Filter / Water Separator

1. Make sure the fuel tank cock (Figure 2, (1)) is closed.

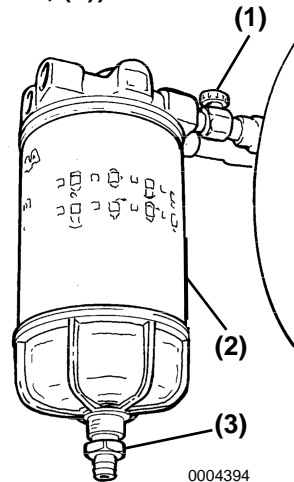

Figure 2

- Loosen the drain plug (**Figure 2, (3)**) at the bottom of the fuel filter / water separator and drain off any water or dirt. **WARNING! ALWAYS wear eye protection. The fuel system is under pressure and fuel could spray out when any fuel system components are removed.**

Note: If the fuel filter / water separator is positioned higher than the fuel level in the fuel tank, water may not drip out when the fuel filter / water separator drain cock is opened. If this happens, turn the air vent screw (if equipped) on the top of the fuel filter / water separator 2–3 turns counterclockwise. Be sure to tighten the air vent screw after the water has drained out.

- Turn the filter container (**Figure 2, (2)**) counterclockwise to remove. **NOTICE: Put an approved container under the opening when removing any fuel system component to perform maintenance (such as changing the fuel filter). Dispose of waste properly.**
- Remove the filter element.
- Lubricate the seal and install a new filter element into the container.
- Install filter container and hand-tighten.
- Open the fuel tank cock (**Figure 2, (1)**).
- After reinstalling the fuel filter and the fuel filter / water separator, bleed air from the fuel system. See *Bleeding the Fuel System* on page 19.

Changing Engine Oil and Replacing the Engine Oil Filter Element

The engine oil on a new engine becomes contaminated from the initial break-in of internal parts. It is very important that the initial oil replacement is performed as scheduled.

It is easiest and most effective to drain the engine oil after operation while the engine is still warm. **WARNING! If you must drain the engine oil while it is still hot, stay clear of the hot engine oil to avoid being burned. ALWAYS wear eye protection.**

- Remove the engine oil dipstick. Attach the oil drain pump (if equipped) and pump out the oil. Dispose of waste properly. **NOTICE: Prevent dirt and debris from contaminating engine oil. Carefully clean the oil cap / dipstick and the surrounding area before you remove the cap.**
For easier draining, remove the engine oil filler cap.

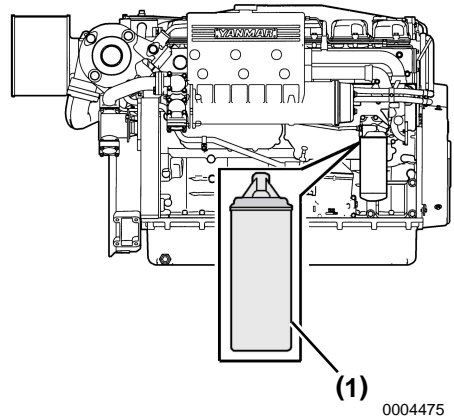

Figure 3

- Remove the filter (**Figure 3, (1)**) with a filter wrench.
- Install a new filter.

*Note: If the deposits in the centrifugal cleaner are more than 20 mm (3/4 in.) thick, replace the oil filter more often. The same is true for cleaning the centrifugal oil cleaner and changing the oil. See *Cleaning the Centrifugal Engine Oil Cleaner* on page 42.*

PERIODIC MAINTENANCE

4. Fill with new engine oil. See *Adding Engine Oil on page 21*. **NOTICE:** *Only use the engine oil specified. Other engine oils may affect warranty coverage, cause internal engine components to seize, or shorten engine life. NEVER mix different types of engine oil. This may adversely affect the lubricating properties of the engine oil.*
5. Perform a trial run and check for oil leaks.
6. Approximately 10 minutes after stopping the engine, remove the oil dipstick and check the oil level. Add oil if the level is too low. **NOTICE:** *NEVER overfill. Overfilling may result in white exhaust smoke, engine overspeed or internal damage. ALWAYS keep the oil level between upper and lower lines on the oil cap / dipstick.*

Cleaning the Centrifugal Engine Oil Cleaner

Clean the centrifugal engine oil cleaner every time the oil is changed.

1. Clean the oil cleaner cover. Turn the nut counterclockwise to remove. Carefully remove the cover in case the oil is hot.

2. Lift out the rotor and turn the nut on the rotor bowl counterclockwise three turns (**Figure 4**).

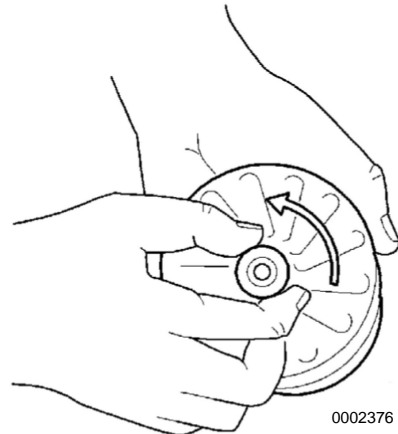

Figure 4

- If the nut is jammed, clamp the nut in a vise and turn the rotor three turns counterclockwise by hand or with a wrench (**Figure 5**). **NOTICE:** *Never clamp the rotor in a vise or strike the rotor bowl. Doing so may cause damage resulting in imbalance.*

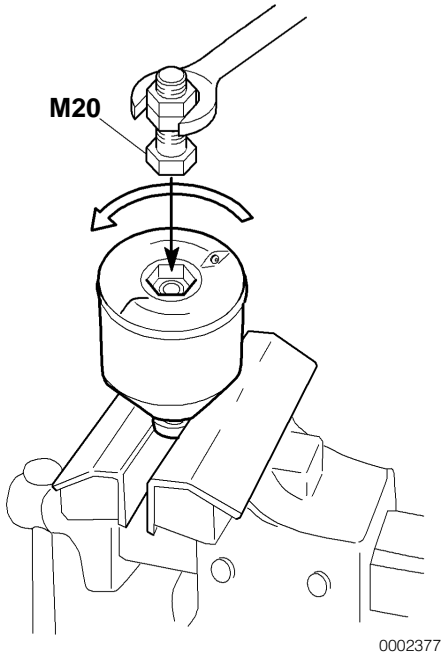

Figure 5

3. Grasp the rotor bowl and tap on the rotor nut with your hand or a plastic hammer to loosen the rotor from the bowl.

4. Remove the strainer located on the rotor (Figure 6). If the strainer is stuck, use a screwdriver to carefully pry the bottom edge until it comes loose from the bottom plate.

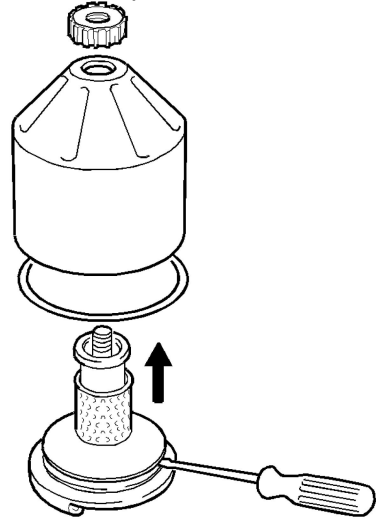

Figure 6

5. Scrape off the deposits from the inside of the rotor bowl (Figure 7).
 - If there are no deposits, the cleaner is not working properly.
 - If the deposits are thicker than 20 mm (3/4 in.), clean the oil cleaner more often.

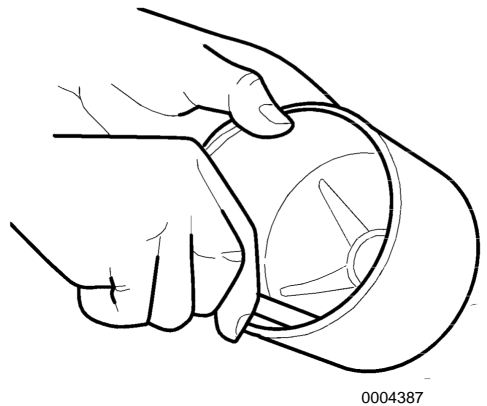

Figure 7

PERIODIC MAINTENANCE

- Wash all of the parts in suitable parts cleaning solvent. **CAUTION! Avoid personal injury. Always wear personal protective equipment when using solvents or chemicals.**
- Make sure the nozzles on the rotor are not blocked or damaged.
- Make sure the bearings are not damaged.
- Inspect the O-ring in the rotor bowl for damage and replace if necessary.
- Install the O-ring in the rotor bowl (**Figure 8**).

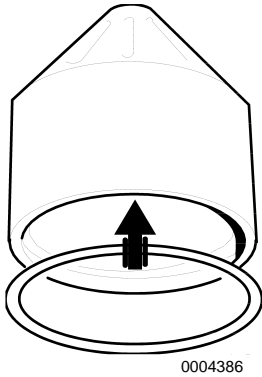

Figure 8

Reassembling the Rotor

- Tighten the rotor nut firmly by hand (**Figure 9**).

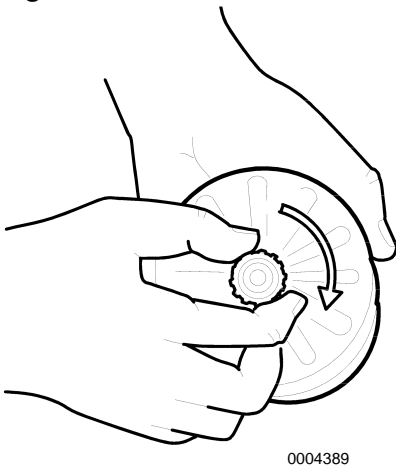

Figure 9

- Make sure the shaft is not loose. If the shaft is loose, see your authorized Yanmar marine dealer or distributor.
- Install the rotor. Turn the rotor by hand to make sure that it rotates easily (**Figure 10**).

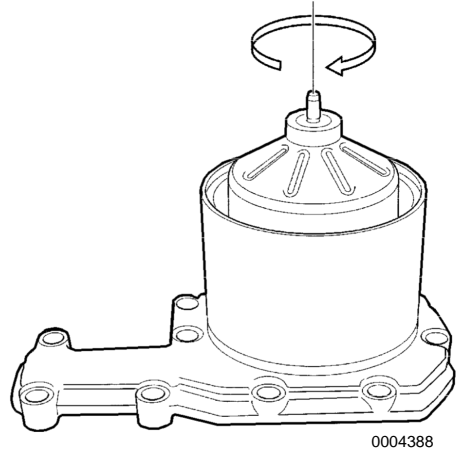

Figure 10

- Install the bowl and tighten the lock nut to 15 N·m (133 in.-lb) (**Figure 11, (1)**). Be careful not to damage the rotor shaft, nut and bowl when tightening the lock nut.

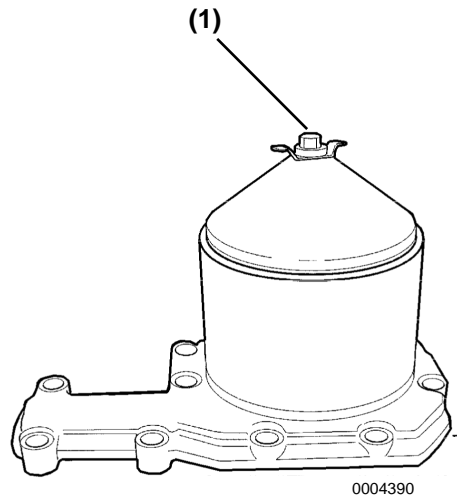

Figure 11

Functional Inspection

The rotor spins very fast and should continue to turn when the engine has stopped.

To check rotor rotation:

1. Stop the engine after it is warm.
2. Listen for a whirring sound from the rotor or check if the cleaner housing is vibrating.
 - The rotor normally continues spinning for 30 - 60 seconds after the engine has stopped.
 - If the rotor does not spin for 30 - 60 seconds after the engine has stopped, disassemble it and inspect the parts for damage.

Checking and Adjusting the Alternator Belt

1. Stop the engine before checking the alternator belt.
2. Check the belt by pushing on the middle of the belt (**Figure 12, (1)**) with your finger, exerting a force of approximately 98 N, 10 kgf (22 lbf).
With proper tension, the belt should deflect 8 - 10 mm (approximately 3/8 in.).

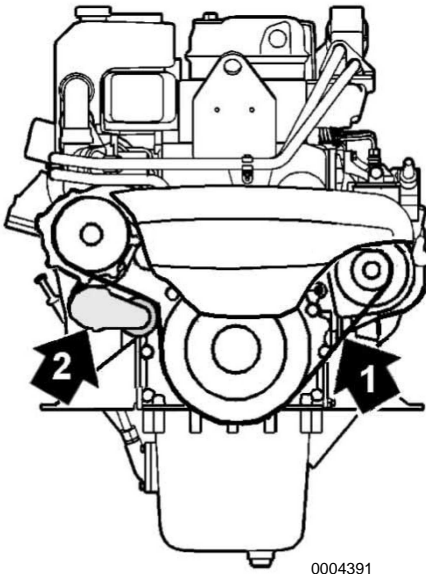

Figure 12

3. If the belt deflection is not to specification, see your authorized Yanmar dealer or distributor for belt replacement. **NOTICE: Do not get any oil on the belt(s). Oil on the belt causes slipping and stretching. Replace the belt if it is damaged.**

Checking Electronic Management System (EMS) Operation

Check for fault codes. Refer to separate manual provided by the digital display manufacturer.

Adjusting Propeller Shaft Alignment

Refer to reverse gear manufacturer literature for alignment procedure.

PERIODIC MAINTENANCE

Every 50 Hours of Operation

After you complete the initial 50 hour maintenance procedures, perform the following procedures every 50 hours or monthly whichever comes first.

- **Draining the Fuel Filter and the Fuel Filter / Water Separator**
- **Checking the Battery Electrolyte Level**

Draining the Fuel Filter and the Fuel Filter / Water Separator

See *Draining or Replacing the Fuel Filter Element and Fuel Filter / Water Separator* on page 40.

Checking the Battery Electrolyte Level (Serviceable Batteries Only)

NOTICE: *NEVER* attempt to remove the covers or fill a maintenance-free battery.

1. Do not operate with insufficient battery electrolyte as the battery will be destroyed.
2. Remove the plugs and check the electrolyte level in all cells. **WARNING! Batteries contain sulfuric acid. NEVER allow battery fluid to come in contact with clothing, skin or eyes. Severe burns could result. ALWAYS wear safety glasses and protective clothing when servicing the battery. If battery fluid contacts the eyes and / or skin, immediately flush the affected area with a large amount of clean water and obtain prompt medical treatment.**

3. If the level is lower than the minimum fill level (**Figure 13, (1)**), fill with distilled water (**Figure 13, (2)**) (available in the grocery store) up to the upper limit (**Figure 13, (3)**) of the battery.

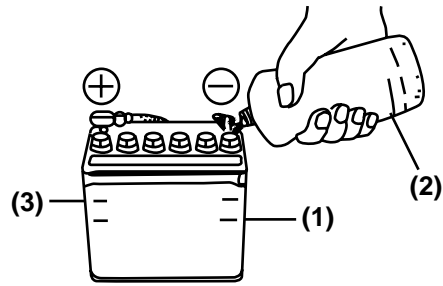

0002388

Figure 13

NOTICE: *Battery fluid tends to evaporate in high temperatures, especially in summer. In such conditions, inspect the battery earlier than specified.*

Note: The maximum fill level is approximately 10 - 15 mm (3/8 - 9/16 in.) above the plates.

Every 250 Hours of Operation

Perform the following maintenance every 250 hours of operation or yearly whichever comes first.

- **Adjusting Intake / Exhaust Valve Clearance (Initial 250 Hours)**
- **Adjusting Unit Injectors / Rocker Arms (Initial 250 Hours)**
- **Draining the Fuel Tank**
- **Replacing the Fuel Filter Element**
- **Changing the Engine Oil**
- **Replacing the Engine Oil Filter Element**
- **Replacing the Closed Crankcase Ventilation Filter Element**
- **Cleaning the Centrifugal Engine Oil Cleaner**
- **Checking the Seawater Pump Impeller**
- **Checking or Replacing the Anodes**
- **Cleaning the Closed Cooling System**
- **Cleaning or Replacing the Air Intake Filter Element**
- **Cleaning Exhaust / Water Mixing Elbow**
- **Cleaning the Turbocharger**
- **Cleaning the Charge Air Cooler**
- **Checking the Wiring Connectors**
- **Tighten All Major Nuts and Bolts**
- **Checking or Replacing the Flexible Engine Mounts**
- **Draining, Flushing and Refilling the Engine Coolant**

Adjusting the Intake / Exhaust Valve Clearance (Initial 250 Hours)

Proper adjustment is necessary to maintain the correct timing for opening and closing the valves. Improper adjustment will cause the engine to run noisily, resulting in poor engine performance and engine damage. See your authorized Yanmar marine dealer or distributor to adjust the intake / exhaust valve clearance.

Checking and Adjusting the Unit Injector / Rocker Arms (Initial 250 Hours)

Proper adjustment is necessary. See your authorized Yanmar marine dealer or distributor to adjust the unit injector rocker arms.

Draining the Fuel Tank

See the boat manufacturer's literature for procedure.

Replacing the Fuel Filter Element

See *Draining or Replacing the Fuel Filter Element* on page 40.

Changing the Engine Oil and Replacing the Engine Oil Filter Element

See *Changing Engine Oil and Replacing the Engine Oil Filter Element* on page 41.

Replacing the Closed Crankcase Ventilation Filter Element

1. Remove the drain line at the filter base.

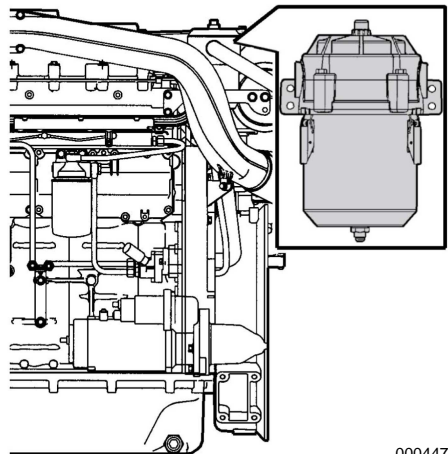

0004476

Figure 14

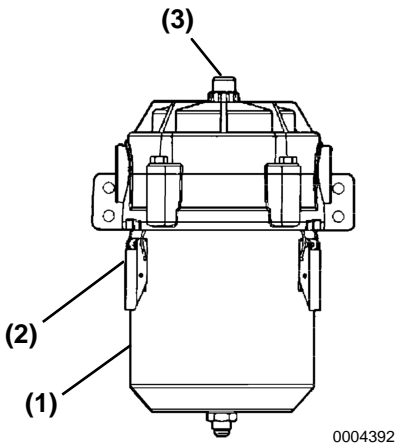

Figure 15

2. Release the clamps (**Figure 15, (2)**) holding the filter container (**Figure 15, (1)**) to the filter head.
3. Remove the filter container (**Figure 15, (1)**) carefully, there may be oil in the bottom of the container.
4. Remove the filter element.
5. Install a new O-ring at the base of the head and check that there is an O-ring on the top of the new filter.
6. Install the new filter into the center of the filter head and press firmly.
7. Replace the container and lock the clamps (**Figure 15, (2)**).
8. If the restriction indicator (**Figure 15, (3)**) on the top of the filter is red, remove the plastic cover and reset the restriction indicator button.
9. Install the drainage line.

Cleaning the Centrifugal Engine Oil Cleaner

See *Cleaning the Centrifugal Engine Oil Cleaner* on page 42.

Checking or Replacing the Seawater Pump Impeller

Depending on use, the inside parts of the seawater pump deteriorate and discharge performance drops.

At the specified interval or when the volume of seawater discharged is reduced, inspect the seawater pump:

1. Close the sea valve (seacock) if the marine water pump is under water.
2. Drain the seawater circuit. **WARNING! Wait until the engine cools before draining seawater from the cooling system. Hot seawater may splash and cause burns.**
3. Remove the marine water pump cap.
4. Check the impeller vanes for wear or damage.

NOTICE: *If the impeller must be changed frequently, the seawater strainer must be replaced with a unit having better filtering capabilities.*

Checking or Replacing the Anodes

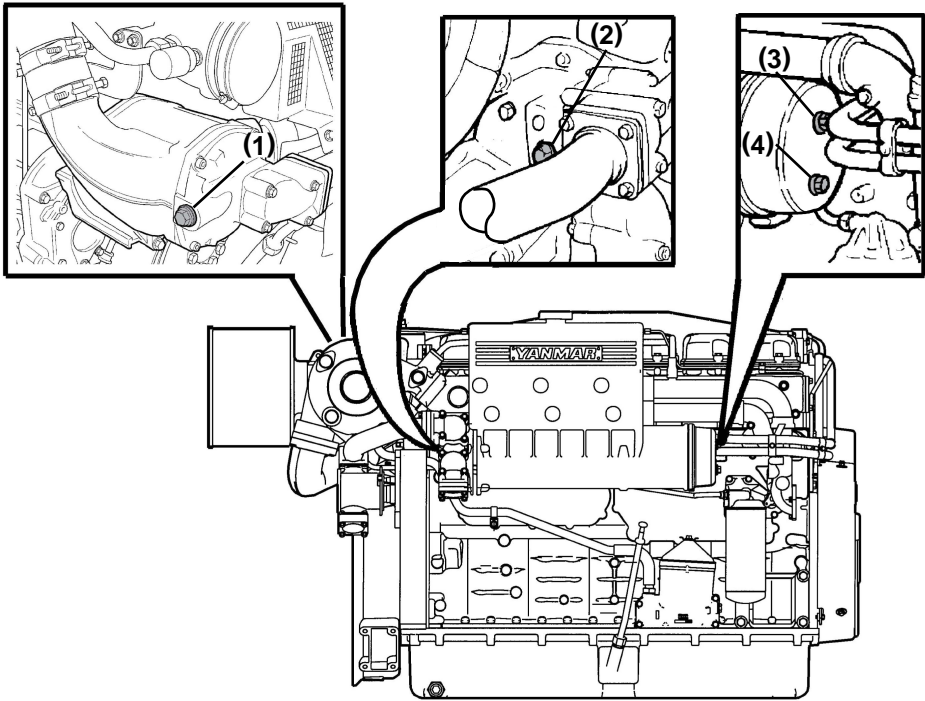

0004395

Figure 16

1. Drain the seawater cooling circuit and check the anodes (**Figure 16**).
2. Scrape off all loose material on the anodes.
3. A new anode is 63 mm (2.50 in.) long with a diameter of 17 mm (11/16 in.). Replace an anode if less than half of the anode remains. **NOTICE:** *NEVER use thread sealer or thread sealing tape when installing zinc anodes. Anodes must make good metal-to-metal contact to perform properly.* **NOTICE:** *If operation is continued with an anode less than half of the new anode length, corrosion of the seawater coolant system will occur and water leakage or parts breakage will result.*

Note: If the anodes are extremely corroded, check them more frequently.

This Page Intentionally Left Blank

Cleaning the Coolant System

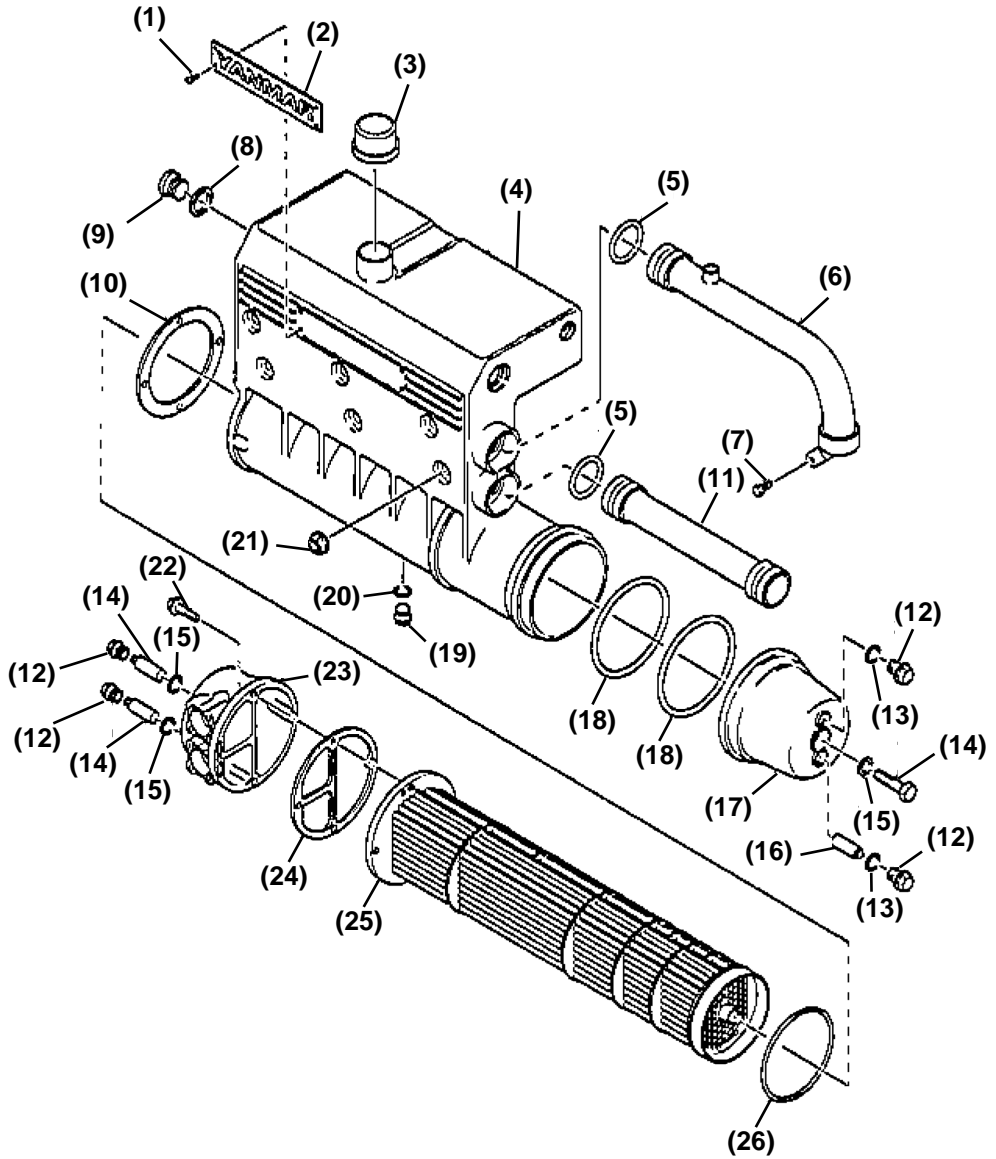

0004399

Figure 17

PERIODIC MAINTENANCE

- | | |
|---------------------------------|---------------------|
| 1 – Screw | 14 – Bolt |
| 2 – Nameplate | 15 – Seal |
| 3 – Filler Cap | 16 – Anode (3 used) |
| 4 – Heat Exchanger Housing | 17 – Front Cover |
| 5 – O-Ring | 18 – O-Ring |
| 6 – Return Pipe to Coolant Pump | 19 – Drain Plug |
| 7 – Bolt | 20 – Gasket |
| 8 – Gasket | 21 – Flange Nut |
| 9 – Plug | 22 – Bolt |
| 10 – Gasket | 23 – Rear Cover |
| 11 – Outlet from Engine | 24 – Gasket |
| 12 – Bolt | 25 – Cooler Core |
| 13 – Seal | 26 – O-Ring |

Internal Cleaning - Heat Exchanger

CAUTION! ALWAYS wear eye protection and rubber gloves when you handle Long Life engine coolant. If contact with the eyes or skin should occur, flush eyes and wash immediately with clean water.

1. Drain the coolant from the engine and from the heat exchanger. See *Draining, Flushing and Refilling the Engine Coolant on page 55*.
2. Drain the seawater circuit by removing the cover from the seawater pump and the connections from the heat exchanger outlet. **WARNING! Wait until the engine cools before draining seawater from the cooling system. Hot seawater may splash and cause burns.**
3. Disconnect the coolant pipes from the charge air cooler. Disconnect the pipe between the front cover and the heat exchanger.
4. Remove the connection housing at the coolant pump inlet together with the return pipe from the heat exchanger.
5. Remove the thermostat housing cover and the outlet pipe to the heat exchanger.
6. Remove the seawater inlet flange from the heat exchanger.
7. Remove the vent pipe from the coolant recovery tank.
8. Remove the flange nuts and lift off the complete heat exchanger assembly.
9. Remove the rear cover and pull out the cooler element.
10. Use paraffin-based engine detergent to clean the element. **NOTICE: NEVER clean the coolant system with caustic soda. The aluminum parts may be damaged.**
11. Any internal deposits in the pipes can be removed with a round rod.
12. Lubricate and install a new O-ring (**Figure 17, (26)**) inside the housing and install the cooler core.
13. Install the front and rear covers using new O-rings and gaskets.
14. Install the heat exchanger assembly on the engine. Tighten the flange nuts to 50 N·m (37 ft-lb).
15. Install the coolant inlet and outlet pipes, thermostat housing cover, connection housing, charge air cooler coolant pipes and thermostat housing.
16. Fill the system with coolant. See *Draining, Flushing and Refilling the Engine Coolant on page 55*.
17. Start the engine and check for coolant leaks. Check the level of the coolant and fill as necessary.

Flushing the Closed Cooling System

1. If possible, run the engine until it has reached operating temperature and then drain the coolant system. See *Draining, Flushing and Refilling the Engine Coolant on page 55*.
2. Remove the thermostats.
3. Fill the system (including the heat exchanger, if equipped) with clean, hot water mixed with liquid dishwasher detergent designed for household use or a product intended to clean automotive cooling systems, and approved for use with aluminum components. **NOTICE: NEVER clean the coolant system with caustic soda. The aluminum parts may be damaged.** Concentration: 1% (0.1 / 10 L) (0.1 / 10 qt).
4. Run the engine until warm (about 20 - 30 minutes).
5. Drain the coolant system. See *Draining, Flushing and Refilling the Engine Coolant on page 55*.
6. Fill the system again using clean, hot water and run the engine for about 20 - 30 minutes.
7. Drain the water from the system.
8. Reinstall the thermostats.
9. Fill the system with new coolant. See *Engine Coolant on page 22* for refilling coolant.
10. Refill the system with hot water and run the engine for about 20 - 30 minutes.
11. Drain the water from the system.
12. Reinstall the thermostats.
13. Fill the system with new coolant. See *Check Diesel Fuel, Engine Oil and Engine Coolant Levels on page 24* for refilling coolant.

Cleaning or Replacing the Air Intake Filter Element

NOTICE: ALWAYS use genuine Yanmar replacement parts (super-fine mesh filter). Using anything except genuine Yanmar parts can cause engine damage, uneven engine performance and shorten engine life.

Note: Replace the air cleaner filter sooner than every 500 hours if the restriction indicator is red.

1. Loosen clamps.
2. Remove the filter element.
3. Carefully blow the filter element clean from the inside with dry compressed air or install new filter element in housing. **CAUTION! ALWAYS wear eye protection when using compressed air. Dust, flying debris or compressed air may injure your eyes.** **NOTICE: There is a risk of damaging the filter when it is cleaned. The filter can only be cleaned a maximum of four times. A cleaned filter does not perform as well as a new filter.**
4. Insert a flashlight into the filter and check from the outside that there are no holes or cracks in the filter paper.
5. Replace the filter if it has the slightest damage.
6. Mark the date the filter has been cleaned.
7. Reassemble the air cleaner in reverse order.
8. Tighten clamps securely.

PERIODIC MAINTENANCE

9. Press the button to reset the red plunger (Figure 18) in the restriction indicator.

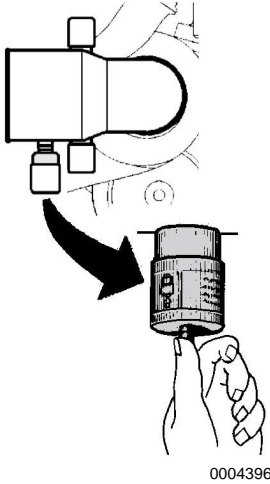

Figure 18

Cleaning the Exhaust / Water Mixing Elbow

See your authorized Yanmar marine dealer or distributor.

Cleaning the Turbocharger

Contamination of the turbocharger causes revolutions to drop and engine output to fall.

If a significant drop in engine output is noted (10% or more), clean the turbocharger.

Cleaning should only be done by a trained and qualified technician. See your authorized Yanmar marine dealer or distributor.

Cleaning the Charge Air Cooler

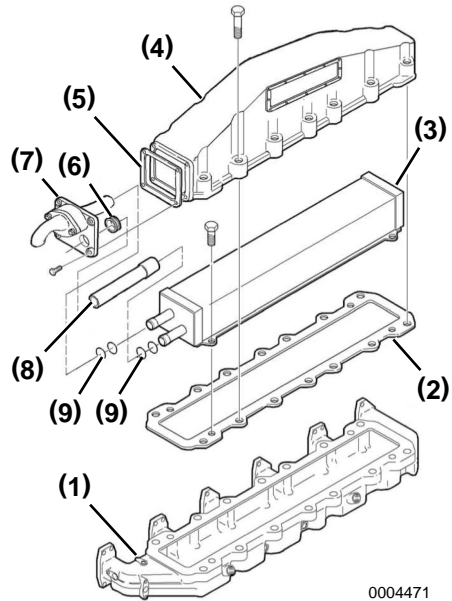

Figure 19

- 1 – Air Intake Manifold, Lower
- 2 – Gasket
- 3 – Charge Air Cooler Element
- 4 – Air Intake Manifold, Upper
- 5 – Gasket
- 6 – V-Ring
- 7 – Cover with Thermostat Housing and Thermostat
- 8 – Connection Pipe
- 9 – O-Ring

1. Drain the coolant from the engine. See *Draining, Flushing and Refilling the Engine Coolant* on page 55.
CAUTION! ALWAYS wear eye protection and rubber gloves when you handle Long Life engine coolant. If contact with the eyes or skin should occur, flush eyes and wash immediately with clean water.
2. Remove the connection pipe between upper intake manifold housings.
3. Disconnect the pipe between intake manifold and turbocharger.

4. Disconnect inlet and outlet water lines from charge air cooler fittings. Seal the fittings with caps or plugs to prevent coolant spillage.
5. Remove the upper intake manifold housing.
6. Remove the charge air cooler assembly from the intake manifold.
NOTICE: *Take care to ensure that no coolant spills from the element into the intake manifold.*
7. Clean the element using paraffin-based engine detergent only. **NOTICE:** *NEVER clean the coolant system with caustic soda. The aluminum parts may be damaged.*
8. Clean and degrease the sealing surfaces on the upper and lower intake manifold housing.
9. Install charge air cooler(s) using a new gasket. Tighten bolts to 20 N·m (177 in.-lb).
10. Install upper intake manifold(s). Tighten bolts to 50 N·m (37 ft-lb).
11. Install connection pipe between intake manifolds.
12. Connect coolant hoses to charge air coolers.
13. Install and secure all remaining air inlet pipes and hoses. Tighten V-clamps to:
 - M6 Screw - 8 N·m (71 in.-lb)
 - M8 Screw - 20 N·m (177 in.-lb)
14. Fill the system with coolant. See *Draining, Flushing and Refilling the Engine Coolant* on page 55.
15. Start the engine and check for coolant leaks. Check the level of the coolant and fill as necessary.

Checking the Wiring Connectors

See your authorized Yanmar marine dealer or distributor.

Tighten All Major Nuts and Bolts

See your authorized Yanmar marine dealer or distributor.

Checking or Replacing the Flexible Engine Mounts

See your authorized Yanmar marine dealer or distributor.

Draining, Flushing and Refilling the Engine Coolant

Cooling performance drops when coolant is contaminated with rust and scale. The coolant must be replaced periodically because its properties deteriorate over time.

1. **WARNING! NEVER remove the coolant filler cap if the engine is hot. Steam and hot engine coolant will escape and can cause serious burns. Allow the engine to cool sufficiently before attempting to remove the filler cap.** **NOTICE:** *Prevent dirt and debris from contaminating engine coolant. Carefully clean the heat exchanger cap and the surrounding area before you remove the cap.*
Remove the filler cap from the coolant recovery tank.

PERIODIC MAINTENANCE

2. Drain the coolant:
 - from the two drain taps on the lower right side of the block (**Figure 20, (2)**)
 - from the drain tap (**Figure 20, (1)**) located on the lower left side of the block
 - from the two holes (remove the plugs) below the heat exchanger (if equipped)

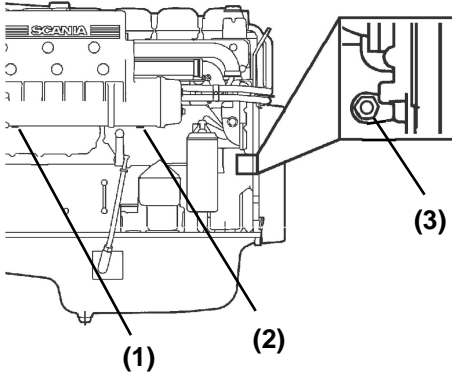

Figure 20

3. Close the drain taps (**Figure 20, (1 and 2)**) and replace the heat exchanger plugs (if equipped).
4. Fill the coolant recovery tank with coolant through the expansion tank fill hole (**Figure 20, (3)**). See *Engine Coolant* on page 22 for refilling coolant. **WARNING! ALWAYS tighten the filler cap securely after checking the coolant level. Steam can escape during engine operation if the cap is loose.**

Every 500 Hours of Operation

Perform the following maintenance every 500 hours of operation or every 2 years, whichever comes first.

- **Replacing the Seawater Pump Impeller**
- **Checking the Alternator Belt Tension**
- **Adjusting the Propeller Shaft Alignment**

Checking or Replacing the Seawater Pump Impeller

Depending on use, the inside parts of the seawater pump deteriorate and discharge performance drops.

At the specified interval or when the volume of seawater discharged is reduced, inspect the seawater pump:

1. Close the sea valve (seacock) if the marine water pump is under water.
2. Drain the seawater circuit. **WARNING! Wait until the engine cools before draining seawater from the cooling system. Hot seawater may splash and cause burns.**
3. Remove the marine water pump cap.
4. Check the impeller vanes for wear or damage.
NOTICE: *If the impeller must be changed frequently, the seawater strainer must be replaced with a unit having better filtering capabilities.*

Replacing the Seawater Pump Impeller

1. Remove the impeller with an impeller removal tool (**Figure 21, (1)**).
2. Install a new impeller and cap. If the cap seal is hard or damaged, replace it.

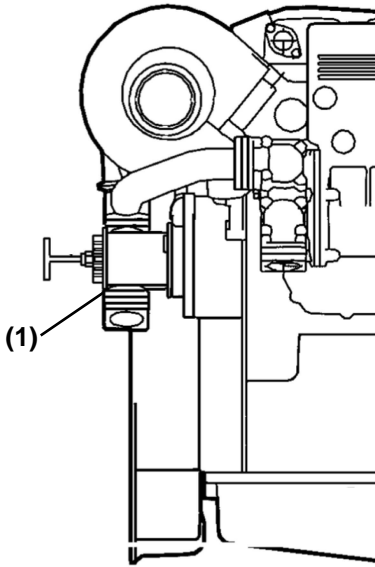

0004400

Figure 21

Note: A spare impeller should be kept on-board.

The impeller can become deformed during long periods of inactivity. Replace or remove the impeller before long periods of storage. See *Prepare Engine for Long-Term Storage* on page 59.

Checking the Alternator Belt Tension

See *Checking and Adjusting the Alternator Belt* on page 45.

Adjusting the Propeller Shaft Alignment

See *Adjusting Propeller Shaft Alignment* on page 45.

Every 1000 Hours of Operation

Perform the following maintenance every 1000 hours of operation or every 4 years, whichever comes first.

- **Adjusting the Unit Injectors / Rocker Arms**
- **Cleaning and Checking the Seawater Passages**
- **Replacing the Alternator Belt**
- **Adjusting the Intake / Exhaust Valve Clearance**
- **Replacing the Flexible Engine Mounts**

Adjusting the Unit Injectors / Rocker Arms

See your authorized Yanmar marine dealer or distributor.

Cleaning and Checking the Seawater Passages

See your authorized Yanmar marine dealer or distributor.

Replacing the Alternator Belt

See your authorized Yanmar marine dealer or distributor.

Adjusting the Intake / Exhaust Valve Clearance

See *Adjusting the Intake / Exhaust Valve Clearance (Initial 250 Hours)* on page 47.

Replacing the Flexible Engine Mounts

See your authorized Yanmar marine dealer or distributor.

Every 2000 Hours of Operation

Perform the following maintenance every 2000 hours of operation or every 8 years, whichever comes first.

- **Overhauling and Checking the Fuel Feed Pump**
- **Replacing the Rubber Fuel Hoses**
- **Cleaning the Engine Oil Cooler**
- **Cleaning the Seawater and Engine Coolant System**
- **Checking the Wiring Connectors**

Overhauling and Checking the Fuel Feed Pump

See your authorized Yanmar marine dealer or distributor.

Replacing the Rubber Fuel Hoses

See your authorized Yanmar marine dealer or distributor.

NOTICE: Replace rubberized fuel hoses every 2 years or every 2000 hours of engine operation, whichever comes first, even if the engine has been out of service.

Cleaning the Engine Oil Cooler

See your authorized Yanmar marine dealer or distributor.

Cleaning the Seawater and Engine Coolant System

See *Cleaning the Coolant System* on page 51.

Checking the Wiring Connectors

See your authorized Yanmar marine dealer or distributor.

LONG-TERM STORAGE

If the engine is not to be used for an extended period of time, special measures should be taken to protect the coolant system, fuel system and combustion chamber from corrosion and the exterior from rusting.

The engine can normally stand idle for up to six months. If it remains unused for longer than this, please contact your authorized Yanmar marine dealer or distributor.

PREPARE ENGINE FOR LONG-TERM STORAGE

Note: If the engine is close to a periodic maintenance interval, perform those maintenance procedures before putting the engine into long-term storage.

1. Wipe off any dust or oil from the outside of engine.
2. Drain water from fuel filters.
3. Drain fuel tank completely or fill the tank to prevent condensation. To reduce the risk of condensation in the fuel tank during winter storage, fill the tank with fuel and treat with diesel fuel stabilizer.
4. Grease the exposed areas and joints of the remote control cables and the bearings of the remote control handle.
5. Seal the air intake, exhaust pipe, etc. to prevent moisture or contamination from entering engine.
6. Completely drain bilge in hull bottom.
7. Waterproof the engine room to prevent rain or seawater from entering.
8. Charge the battery once a month to compensate for battery's self-discharge.
9. Remove key from key switch and cover the key switch with moisture cap.

NOTICE: If seawater is left inside of the engine, it may freeze and damage parts of the cooling system when the ambient temperature is below 0°C (32°F).

This Page Intentionally Left Blank

SPECIFICATIONS

PRINCIPAL ENGINE SPECIFICATIONS

Engine Model	6SY-STP2 / 6SY655	
Number of Cylinders	In-line 6	
Type	Water-cooled, turbocharged	
Combustion System	Direct injection	
Aspiration	Turbocharged with intercooler	
Bore x Stroke	127 mm x 154 mm (5.0 in. x 6.1 in.)	
Displacement	11.7 L (714 cu in.)	
Firing Order	1-5-3-6-2-4	
Compression Ratio	16:1	
Rated output at crankshaft		
	Output at rev speed	6SY-STP2: 530 kW (720 hp) at 2300 rpm 6SY655: 481 kW (655 hp) at 2300 rpm
	Break mean effective pressure	1.97 MPa (287.5 psi)
Idle Speed		
	High idle	2400 rpm
	Low idle	600 rpm
Rotation Direction	Counterclockwise (viewed from flywheel)	
No. of Valves		
	Inlet	2
	Exhaust	2
Turbocharger	Single water-cooled	
Electrical System	2-pole, 24 V*	
Starter	6.7 kW (9.0 hp)	
Charging System	65 A at 24V*	
Battery Capacity - Recommended	160 Ah	
Injection Timing	Variable (EMS controlled)	
Permissible Value for Exhaust Back Pressure	9.8 kPa (1000 mmAq)	
Cooling System	Closed cooling system with seawater heat exchanger	
	Coolant capacity with expansion tank	40 L (10.5 gal)

SPECIFICATIONS

Engine Model		6SY-STP2 / 6SY655
Thermostats		
	Coolant thermostat type and opening temperature	Dual - 75°C (167°F)
	Charge air cooler type and opening temperature	Single - 50°C (122°F)
Seawater Pump		Rubber impeller, gear driven
	Capacity	315 L / min at 2300 rpm (83 gpm at 2300 engine rpm)
Gear Oil Cooler Restriction		150 mbar (0.03495 psi)
Lubrication System		Totally enclosed, forced lube system
	Oil cooler	Closed coolant system
	Lube oil pressure - Rated speed	300 - 600 kPa (44 - 87 psi)
	Lube oil pressure - Idling speed	150 kPa (22 psi)
	Lube system capacity (with filters)	21 - 31 L (6 - 8.2 gal) approximate
Crankcase Ventilation		Closed, with filter
Engine Size		
	Height	1038 mm (40.9 in.)
	Length	Overall - 1559 mm (50.9 in.) Front Bell Housing - 1366 mm (53.8 in.)
	Width	867 mm (34.1 in.)
	Weight	1150 kg (2535 lb)

* Optional dual 65 A alternators available

EPA WARRANTY USA ONLY

YANMAR CO., LTD. LIMITED EMISSION CONTROL SYSTEM WARRANTY - USA ONLY

THIS EMISSION WARRANTY APPLIES TO THE ENGINES CERTIFIED TO UNITED STATES EPA 40 CFR 94 AND SOLD BY YANMAR THAT ARE INSTALLED IN VESSELS FLAGGED OR REGISTERED IN THE UNITED STATES.

Your Warranty Rights and Obligations:

Yanmar warrants to the first user and each subsequent purchaser the emission control system on your engine for periods of time listed below provided the engine has been installed according to Yanmar installation requirements and there has been no abuse, neglect, or improper maintenance of your Yanmar marine engine.

Yanmar warrants that the engine is designed, built and tested using genuine parts and equipped so as to conform to all applicable emission requirements of the U.S. Environmental Protection Agency and is free from defects in material and workmanship which would cause this engine to fail to conform to the applicable emission regulations over its limited emission control system warranty period.

Where a warrantable emissions condition exists, Yanmar will repair your engine at no charge to you for diagnosis, parts, and labor. Warranty service or repair will be provided at authorized Yanmar marine dealers or distributors.

It is recommended that any replacement parts used for maintenance, repair or replacement of emission control systems are Yanmar parts. The owner may elect to have maintenance, replacement or repair of the emission control components and systems performed by any repair establishment or individual and may elect to use parts other than Yanmar parts for such maintenance, replacement or repair. However, the cost of such service or parts and subsequent failures from such service or parts will not be covered under this emission control system warranty:

Warranty Period:

The warranty starts on either the date of delivery to the first end-user, or the date the unit is first leased, rented, or loaned.

For Pleasure Use: The warranty period is **five (5) years** or **2000 hours** of use, whichever occurs first. In the absence of a device to measure hours of use, the engine has a warranty period of **five (5) years**.

Warranty Coverage:

Repair or replacement of any warranted parts will be performed at an authorized Yanmar dealer or distributor. This limited emission control system warranty covers engine components that are a part of the emission control system of the engine as delivered by Yanmar to the original retail purchaser. Such components may include the following:

1. Fuel Injection System
2. Turbocharger System
3. Aftercooler
4. Electronic Engine Control Units and its associated Sensor and Actuators

Exclusions:

Failures other than those arising from defects in material and / or workmanship are not covered by this limited emissions warranty. This warranty does not extend to the following: malfunction caused by abuse, misuse, improper adjustment, modification, alteration, tampering, disconnection, improper or inadequate maintenance, improper storage or use of non-recommended fuels and lubricating oils, accident-caused damage, and replacement of expendable and / or consumable items made in connection with scheduled maintenance.

Yanmar disclaims any responsibility for incidental or consequential damages such as loss of time, inconvenience, loss of use of marine vessel / engine or commercial loss.

Owner's Responsibility:

As the Yanmar marine engine owner, you are responsible for the performance of the required maintenance listed in your *Operation Manual*. Yanmar recommends that you retain all documentation, including receipts, covering maintenance on your marine engine, but Yanmar cannot deny warranty solely for the lack of receipts or for your failure to ensure the performance of all scheduled maintenance.

Your engine is designed to operate on diesel fuel only. Use of any other fuel may result in your engine no longer operating in compliance with applicable emission requirements. You are responsible for initiating the warranty process. You must present your marine engine to an authorized Yanmar dealer or distributor as soon as a problem exists.

Customer Assistance:

If you have any questions regarding your warranty rights and responsibilities or would like information on the nearest authorized Yanmar dealer or distributor, you should contact Yanmar Marine USA Corporation for assistance.

Yanmar Marine USA Corporation

101 International Parkway

Adairsville, GA 30103

USA Telephone: 770-877-9894

Fax: 770-877-7567

Declaration of Conformity for Recreational Craft Propulsion Engine with the Exhaust emission requirements of Directive 94/25/EC as amended by 2003/44/EC
(To be completed by manufacturer of inboard engines without integral exhaust)

Name of engine manufacturer: Scania CV AB

Street: 87 Town: Södertälje

Post Code: SE-151 Country: Sweden

Name of Authorised Representative: Yanmar Marine International B.V.

Street: Brugplein 11 Town: Almere-de Vaart

Post Code: 1332 BS Country: The Netherlands

Name of Notified Body for **exhaust emission assessment**: DNV, Det Norske Veritas

Street: 104 25 Town: Stockholm

Post Code: Box 30234 Country: Sweden ID Number: 0575

Module used for exhaust emission assessment: B+C B+D B+E B+F G H

or engine type-approved according to: stage II of Directive 97/68/EC Directive 88/77/EC

Other Community Directives applied: 89/336/EEC

DESCRIPTION OF ENGINE(S) AND ESSENTIAL REQUIERMENTS

Engine Type:

- z or sterndrive without integral exhaust
 Inboard engine

Fuel Type:

- Diesel Petrol
 2 stroke 4 stroke

Combustion cycle:

Essential requirements	Standards Used	Other normative document used	See technical file
Annex I.B – Exhaust Emissions			
engine identification			
exhaust emission requirements	EN ISO 8178-1:1996		X
durability			
owner's manual			
Annex I.C – Noise Emissions	see craft manufacturer's Declaration of Conformity		

ENGINE(S) COVERED BY THIS DECLARATION

Engine model(s) or engine family name(s):	EC Type certificate number (exhaust)
8SY-STP	RCD-H3
6SY-STP	
6SY-STP2	
6SY655	

I declare on behalf of the engine manufacturer that the engine(s) will meet the exhaust emission requirements of Directive 94/25/EC as amended by Directive 2003/44/EC when installed in a recreational craft, in accordance with the engine manufacturer's supplied instructions and that this (these) engine(s) must not be put into service until the recreational craft into which it is (they are) to be installed has been declared in conformity with the relevant provisions of the above mentioned Directive.

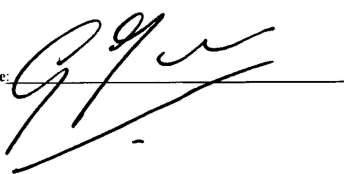
Name: G. J. Mantel President, Yanmar Marine International B.V. Signature and title: 
(identification of the person empowered to sign on behalf of the engine manufacturer or his authorised representative) (or an equivalent marking)

Date: (yr/month/day) 2005 / 12 / 28

This Page Intentionally Left Blank