

Yanmar type 2YM15

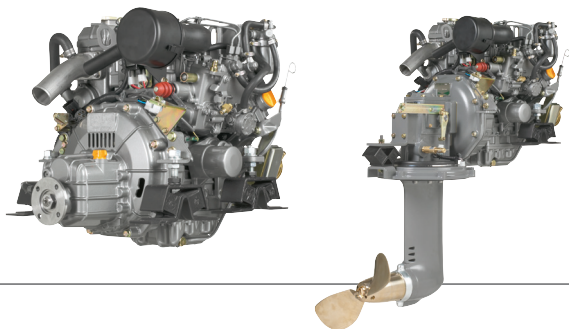

Configuration	4-stroke, vertical, water cooled diesel engine
Maximum output at crankshaft	* 10.3 kW (14 mhp) / 3600 rpm ** 10.0 kW (13.6 mhp) / 3600 rpm
Continuous rating output at crankshaft	9.4 kw (12.8 mhp) / 3489 rpm
Displacement	0.570 L (34.7 cu in)
Bore x stroke	70 mm x 74 mm (2.75 in x 2.91 in)
Cylinders	2
Combustion system	Indirect injection
Aspiration	Natural aspiration
Starting system	Electric starting 12 V - 1.4 kW
Alternator	12 V - 60 A (80A Optional)
Cooling system	Fresh water cooling with heat exchanger
Lubrication system	Enclosed, forced lubricating system
Direction of rotation (crankshaft)	Counter clockwise viewed from flywheel side
Dry weight without gear	103 kg (227 lbs)
Environmental	EU RCD, US EPA Tier 2, BSO II & EMC
Engine mounting	Rubber type flexible mounting

NOTE: Fuel condition: Density at 15°C = 0.84 g/cm³; 1kW = 1.3596 mhp = 1.3410 HP

* Fuel temperature 25°C at the inlet of the fuel injection pump (ISO 3046-1)

** Fuel temperature 40°C at the inlet of the fuel injection pump (ISO 8665 : 2006)

Technical data is according to ISO 8665 / 3046

Dimensions (For detailed line-drawings, please refer to our web-site: www.yanmarmarine.com)

Rear view

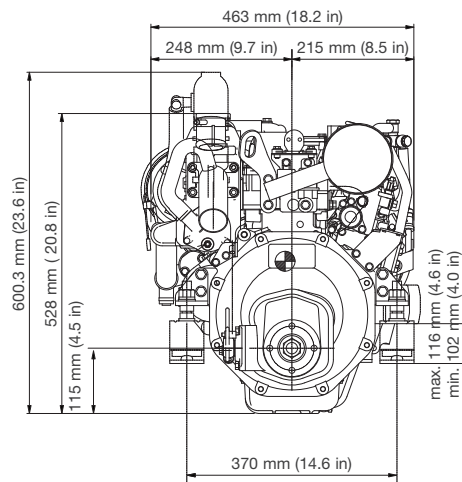

Right side view

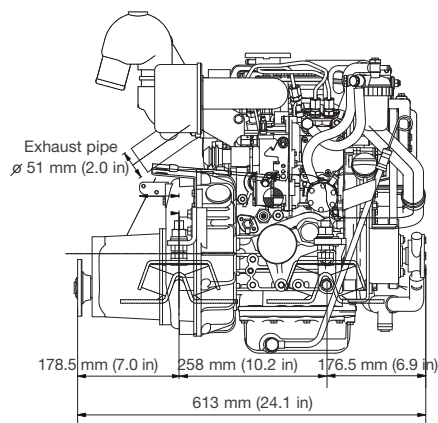

2YM15 with KM2P-1 marine gear

Performance Curves (Output is according ISO 8665)

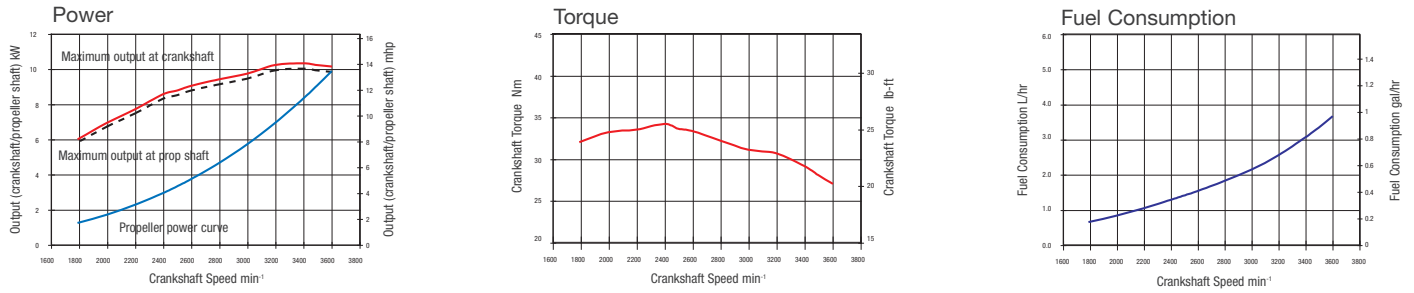

Marine Gears/Drive

Model	KM2P-1			Saildrive (SD20)	KM3V (V-drive)		
Type	Constant mesh gear with servo-cone clutch			Constant mesh gear with dog clutch	Constant mesh gear with servo-cone clutch		
Dry weight	10 kg (22 lbs)			30 kg (66 lbs)	19 Kg (42 lbs)		
Reduction ratio (fwd/asn)	2.21/3.06	2.62/3.06	3.22/3.06	2.64/2.64	2.36/3.16	2.61/3.16	3.20/3.16
Propeller speed (fwd/asn)	1629/1176	1374/1176	1118/1176	1363/1363	1441	1303	1063
Direction of rotation (propeller shaft - fwd)	Clockwise viewed from flywheel side			Counter clockwise viewed from flywheel side	Clockwise viewed from flywheel side		
Dry weight engine and gear/drive	113 kg (249 lbs)			134 kg (295 lbs)	90 kg (198 lbs)		
Length engine and gear/drive	613 mm (24 in)			793 mm (31 in)	680 mm (27 in)		

Instrument Panels

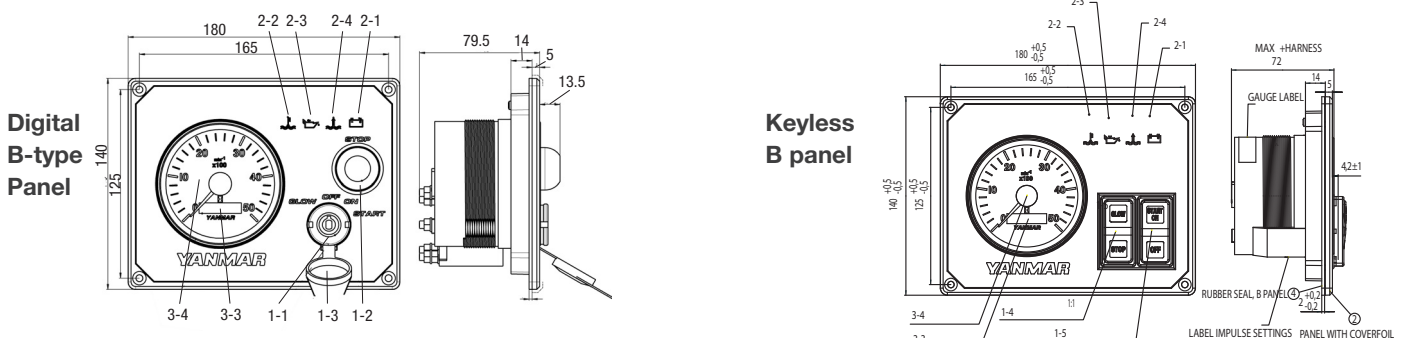

Function	Type of instrument panel	Type of instrument panel
	Digital B-type Panel	Keyless B-type Panel
① Switch unit		
1-1 Key switch for GLOW/OFF/ON/START (4-position switch)	O	X
1-2 Push button switch for engine stop	O	X
1-3 Moisture cap for key switch	O	X
1-4 Rocker switch for Glow/Stop	X	O
1-5 Rocker switch for On/Off/Start	X	O
② Alarm lamp unit		
2-1 Battery low charge alarm	O	O
2-2 Coolant high temperature alarm	O	O
2-3 Lubricating oil low pressure	O	O
2-4 Water in sail drive seal alarm	O	O
2-5 Water in fuel filter alarm	X	X
2-6 Sea water insufficient flow alarm	X	X
③ Meters		
3-1 Lubricating oil pressure meter	X	X
3-2 Coolant temperature meter	X	X
3-3 Hour meter	O	O
3-4 Tachometer	O	O
④ Audible alarm buzzer	O	O

Note: O = Equipped on panel X = Not equipped on panel

Accessories

Standard Package

- Set of flexible mounts
- Exhaust/water mixing elbow L type
- V-belt safety cover
- Expansion tank for fresh water cooling system
- Alternator 12 V - 60 A
- Electric stop solenoid

Optional

- Digital B Panel Horizontal
- 3M / 6M Extension Wire harness
- High Riser Mixing Elbow U type (Instead of L-Elbow)
- Alternator 80A + Belt Cover (Instead of 60A)
- Hotwaterkit with or without cocks
- Dual Harness (For 2nd Station)
- Cone Nut Kit SD20 (For SD20)

Texts and illustrations are not binding. Yanmar Marine reserves the right to introduce adaptations without prior notification.

Version: 2008-06